

# Dimension® BST/SST 1200es

3D Printer

User Guide



## Legal Notice

The only warranties for Stratasys products and services are set forth in the express warranty statement accompanying such products and services. Nothing herein should be construed as constituting an additional warranty. Stratasys shall not be liable for technical or editorial errors or omissions contained herein.

© 2013 Stratasys Inc. All rights reserved. Stratasys, Dimension, uPrint, Catalyst, FDM, Dimension BST, Dimension SST, WaveWash, and Ecoworks are registered trademarks of Stratasys Inc. FDM Technology, Fused Deposition Modeling, *ABSplus*, Catalyst EX, and Smart Supports are trademarks of Stratasys, Inc. All other trademarks are the property of their respective owners, and Stratasys assumes no responsibility with regard to the selection, performance, or use of these non-Stratasys products. Product specifications are subject to change without notice.

---

# Table of Contents

<b>1 Introduction.....</b>	<b>1</b>
How To Use This Manual .....	2
Learn More!.....	2
Recycling .....	2
Safety precautions .....	2
<b>2 Overview.....</b>	<b>4</b>
<b>3 Setup.....</b>	<b>9</b>
Unpacking.....	9
Installing Forklift Access Covers.....	11
Networking the printer .....	12
Power Connections.....	13
Powering On .....	14
Installing software.....	15
Establishing network communication with the printer.....	16
Installing System Software on printer.....	19
Insert Modeling Base .....	20
<b>4 Operation .....</b>	<b>21</b>
Display Panel and Keypad .....	21
System software overview.....	22
CatalystEX overview .....	23
Processing your STL file for printing .....	24
Inserting a Modeling Base .....	26
Building a part.....	26
Loading Material.....	27
Unloading Material .....	30
Building a Test Part.....	31
The display panel during build.....	31
Chamber Lights .....	31
Pausing Build .....	31
Resuming Build from Pause Mode.....	32
Resuming Operations from Standby Mode.....	32
Canceling a Job .....	32
Auto power down .....	32

Powering Off .....	33
Removing a Completed Part.....	33
Removing Support Material .....	34
<b>5 Maintenance .....</b>	<b>35</b>
Startup Kit Tools .....	35
Daily .....	35
Clean fan filter .....	38
Replace the tip wipe assembly .....	38
Tip shield replacement .....	40
Liquefier Tip Replacement.....	44
Chamber Light Bar .....	49
<b>6 Troubleshooting .....</b>	<b>50</b>
Troubleshooting Checklist .....	50
Fault determination codes.....	51
Exporting printer configuration (.cfg) file .....	51
Cycling power .....	52
Diagnosing loss of extrusion .....	52
Clogged tip .....	53
Material Jam.....	54
Recovering from loss of extrusion.....	56
<b>7 Support.....</b>	<b>60</b>
<b>8 Recycling .....</b>	<b>61</b>
<b>9 Printer Specifications .....</b>	<b>62</b>
Physical specifications.....	62
Facility specifications .....	62
Workstation specifications.....	63
Power specifications .....	63
Environmental specifications .....	63
<b>10 Supplemental Information.....</b>	<b>64</b>
Stratasys Limited Warranty Statement .....	64
Declaration of Conformity .....	64
Regulatory and environmental information .....	65
<b>11 Appendix.....</b>	<b>A1</b>
Uninterruptible Power Supply (UPS) Use and Installation.....	A1

---

# 1 Introduction

Dimension 1200es printers are designed with ultimate simplicity in mind. The systems enable you to build parts quickly, even if you have never used a 3D printer before.

The systems model with ABS*plus*<sup>™</sup> plastic, so modeled parts are strong and durable. ABS*plus* also ensures that you will be able to drill, tap, sand, and paint your creations. With the speed and convenience of Soluble Support Technology, completed parts are quickly available for review and test.

Dimension 1200es printers are an innovative combination of proprietary hardware, software, and material technology.

*Congratulations...*

*you made a smart choice!*

## How To Use This Manual

This User's Guide is laid out in easy to follow sections which cover Set-up, Operation, Maintenance, and Troubleshooting. Be sure to read each section carefully so that you will get the best performance from your system.

Throughout this User Guide, text representing **Interface Messages** that appear on the display panel are presented in a bold font.

## Learn More!

An electronic User Guide is available on the User Guide CD. This guide provides information on the following topics:

- Troubleshooting information
- Important safety notices and regulatory information
- Detailed user instructions

You can also find more information at: <http://www.stratasys.com> or email [info@stratasys.com](mailto:info@stratasys.com)

## Recycling

Visit <http://www.stratasys.com/recycle> for recycling information.

## Safety precautions

The following precautions ensure the proper use of the printer and prevent the printer from being damaged. Follow these precautions at all times.

- Use the power supply voltage specified on the nameplate. Avoid overloading the printer's electrical outlet with multiple devices.
- Ensure the printer is well-grounded. Failure to ground the printer may result in electrical shock, fire and susceptibility to electromagnetic interference.
- Before disassembling or repairing the printer yourself, contact your local Service Representative. See Support section of User Guide.
- Use only the power cord supplied with the printer. Do not damage, cut or repair the power cord. A damaged power cord has risk of fire and electric shock. Replace a damaged power cord with an approved power cord.
- Do not allow metal or liquids to touch the internal parts of the printer. Doing so may cause damage, fire, electric shock or other serious hazards.
- Power off the printer and disconnect the power cord from the power outlet in any of the following cases:
  - If there is smoke or an unusual smell coming from the printer.
  - If the printer is making an unusual noise not heard during normal operation.
  - A piece of metal or a liquid touches the internal parts of the printer.
  - During an electrical (thunder/lightning) storm
  - During a power failure

The following classifications are used throughout this guide.



**CAUTION:** Indicates a potentially hazardous situation which, if not avoided, may result in minor or moderate injury.

---



**WARNING:** Indicates a potentially hazardous situation which, if not avoided, could result in serious injury.

---



**Hot Surface:** The hot surface sign indicates the presence of devices with high temperatures. Always use extra care, and wear safety gloves, when working around heated components

---



**Gloves:** When performing some maintenance procedures, the machine may be hot and gloves will be required to avoid burns.

---



**Safety Glasses:** Wear safety glasses to avoid injury to your eyes.

---



**Recycle:** Use proper recycling techniques for materials and packaging.

---



**ESD Sensitive!**

**ESD:** Use standard electrostatic discharge (ESD) precautions when working on or near electrical components.

---

---

## 2 Overview

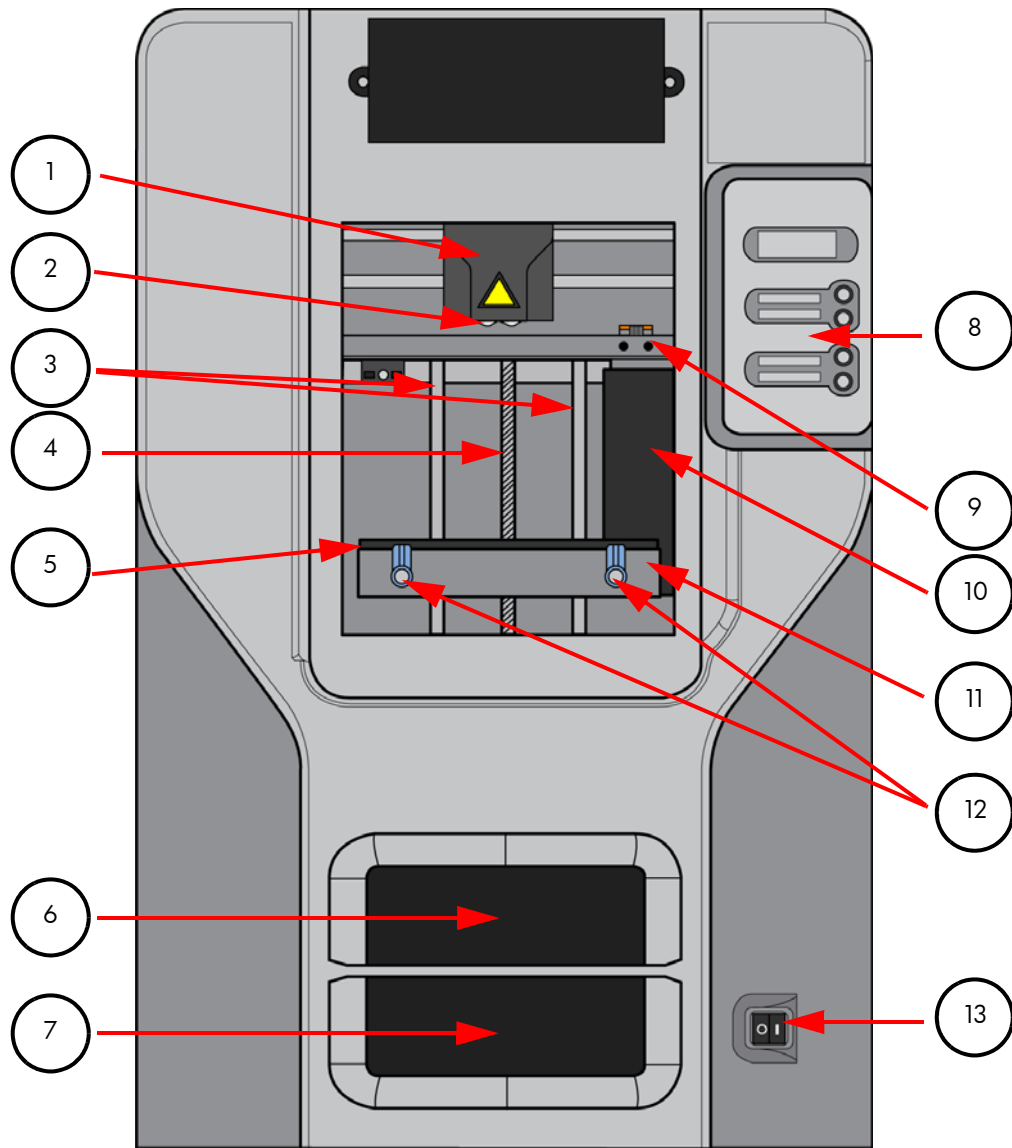
Dimension 1200es printers build models, including internal features, from CAD STL files. Three-dimensional parts are built by extruding a bead of ABS plastic through a computer-controlled extrusion head, producing high quality parts that are ready to use immediately after completion. With two layer resolution settings, you can choose to build a part quickly for design verification, or you can choose a finer setting for higher quality surface detail.

The Dimension 1200es systems consist of two primary components — the Dimension 1200es 3D printer and CatalystEX. CatalystEX is the preprocessing software that runs on a Windows Vista or Windows 7 platform.

The build envelope measures 254 x 254 x 305 mm (10 x 10 x 12 in). Each material cartridge contains 922 cc (56.3 cu. in.) of usable material.

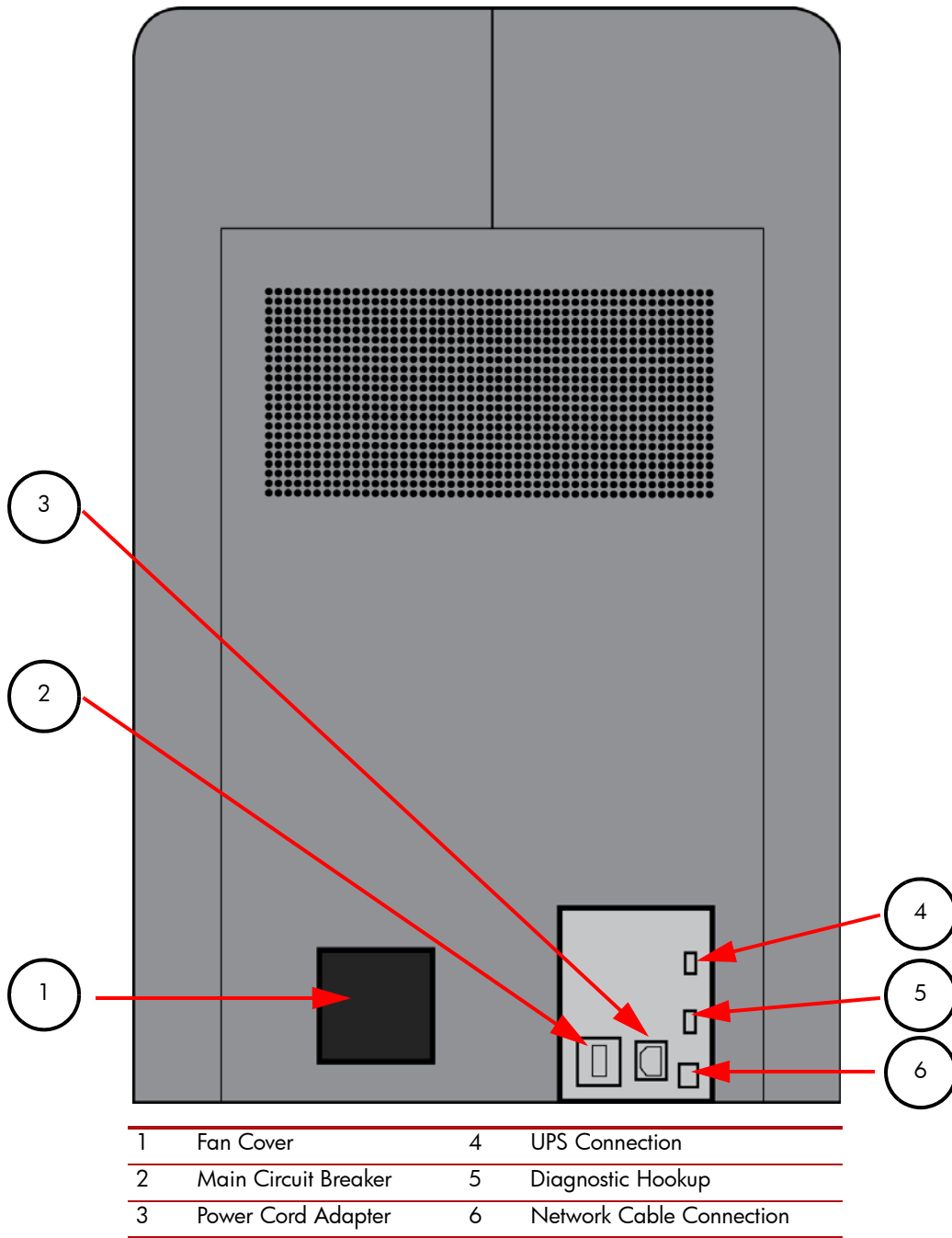


**Figure 1: Front view**

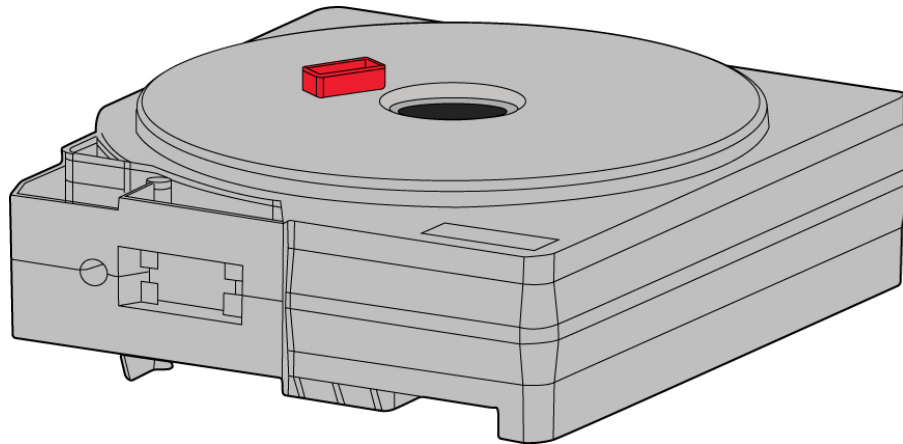


1	Extrusion Head	8	Display Panel
2	Extrusion Tips	9	Tip Cleaning Assembly
3	Guide Rods	10	Purge Container
4	Lead Screw	11	Z stage platen
5	Modeling Base	12	Modeling Base Retainers (2)
6	Model Material Cartridge	13	Power Switch
7	Support Material Cartridge		

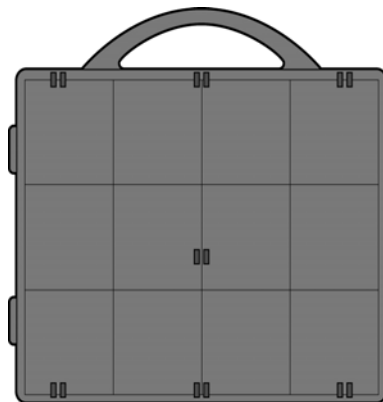
**Figure 2: Rear view**



**Figure 3** Material cartridge



**Figure 4** Modeling base



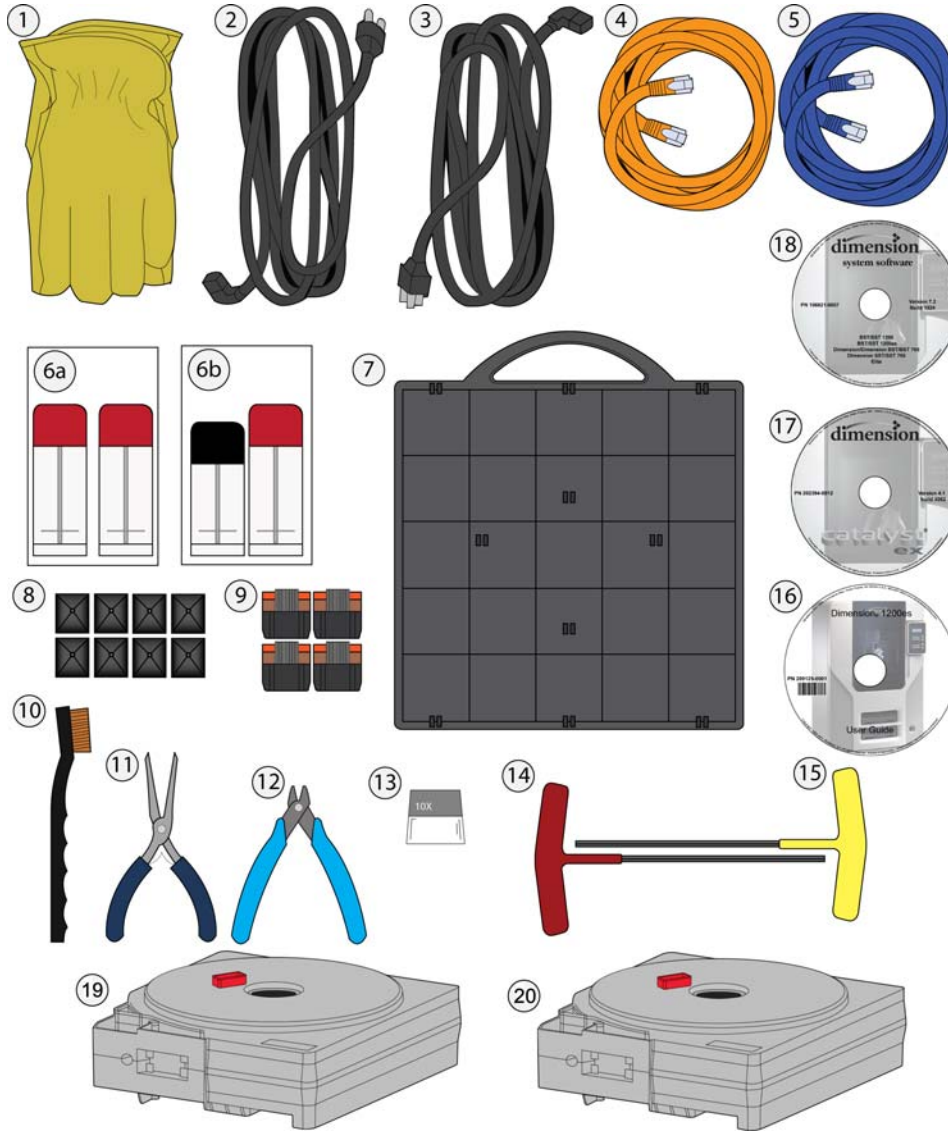
Modeling base



**CAUTION:** DO NOT reuse modeling bases. If a modeling base is reused, calibration errors, poor part quality, and loss of extrusion may occur. Additional modeling bases are available from your reseller.

---

**Figure 5 Startup Supplies**



1	Insulated Leather Gloves (Pair)	10	Bronze Brush
2	Power Cord (Europe)	11	Needle Nose Pliers
3	Power Cord (U.S.)	12	Cutters
4	Crossover Cable (Orange)	13	10x Magnifier Loupe
5	Network Cable (Blue)	14	1/8" T-Handle Allen wrench (red)
6a	BST 1200es model and support tips	15	7/64" T-Handle Allen wrench (yellow)
6b	SST 1200es model and support tips	16	Dimension 1200es User Guide CD
7	Modeling Base (6)	17	CatalystEX CD
8	Tip shield (8)	18	Dimension System Software CD
9	Tip Wipe assembly (4)	19	P430 Model Material Cartridge (ivory) (1)
		20	P400 SR Soluble Support Material Cartridge (1)

---

# 3 Setup

## Unpacking

This section describes the recommended procedures for unpacking and preparing the printer for its first use.

### Unpack the printer:



**WARNING:** The printer weighs approximately 148 kg (326 lbs). Use proper moving and lifting techniques when positioning the unit. For your convenience, there are forklift pads built into the bottom of the unit. They are accessible from the side of the unit.

---

1. Before unpacking the printer, move it near to its operating location.
2. Remove the plastic banding from around the cardboard.
3. Remove the top cover. Set aside the fork access covers (2) and bag of screws (2).
4. Remove screws (4) that attach cardboard to pallet and remove the cardboard side panels.
5. Remove the top foam.
6. Remove outer plastic wrap - use care if using a knife so as to not scratch the printer.
7. Remove the foam door channels (2) and tape.



**WARNING:** The Lead Screw and Guide Rods are lubricated with a thin coat of Krytox grease. Krytox grease can cause skin irritation. Be careful not to get the grease on your hands or clothing.

---



**CAUTION:** Remove the foam tubes that isolate the extrusion head from the frame, see [Figure 6](#). The printer will be damaged if powered on with the foam tubes in place.

---

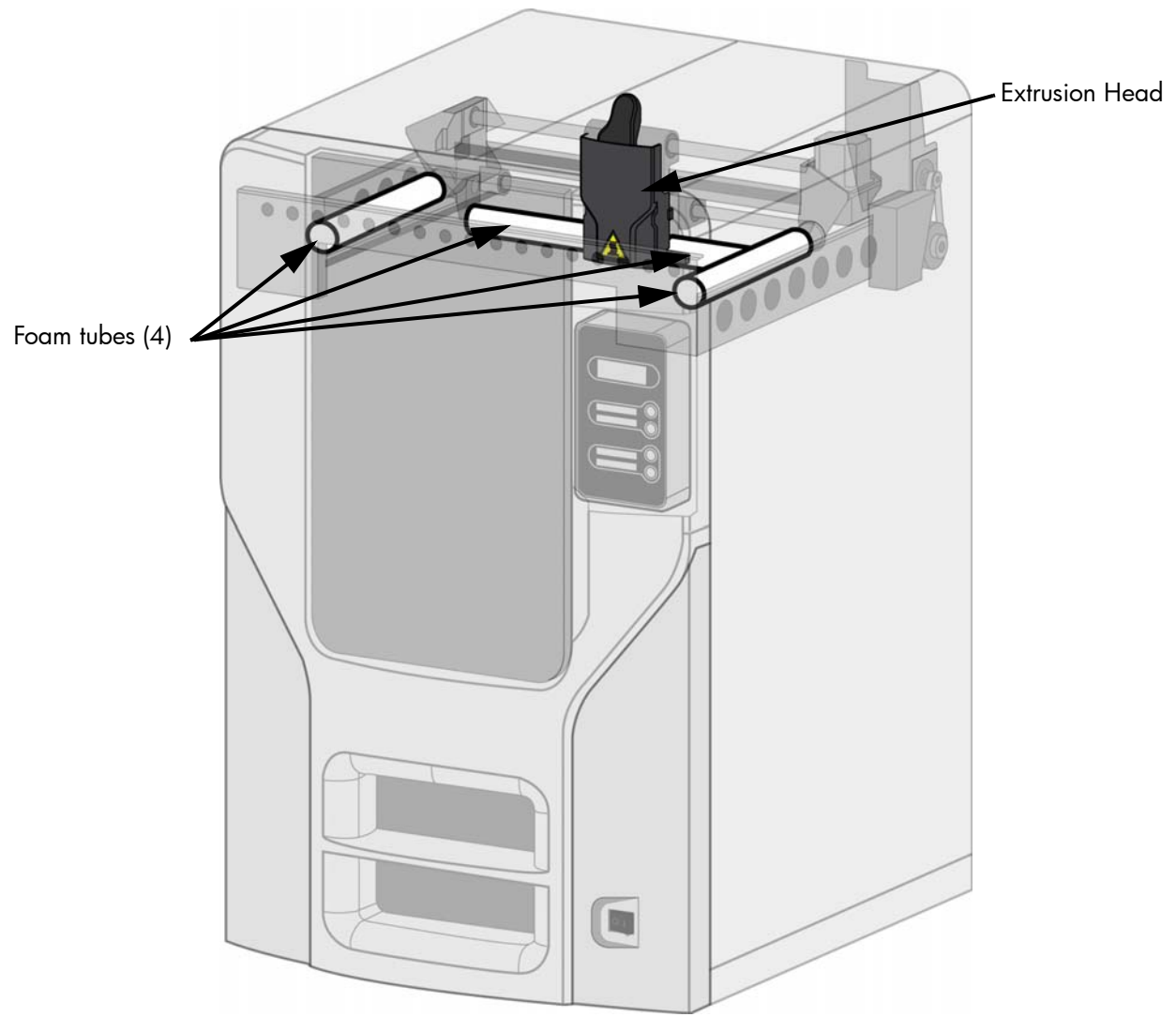


**CAUTION:** Be careful not to damage the rod sensors when removing the foam tubes, see [Figure 6](#).

---

8. Remove the foam tubes that isolate the extrusion head from the frame, see [Figure 6](#).

**Figure 6:** Foam tubes isolating the extrusion head from the XY-axis frame



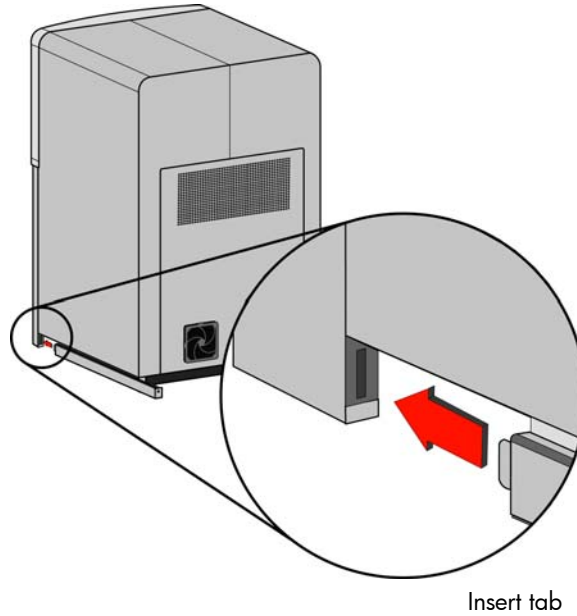
9. After unpacking, inspect the printer and report any shipping damage to the carrier.

## Installing Forklift Access Covers

The forklift access covers can be placed over the forklift channels after the printer is placed in its final location. The covers are press-fit in the front and held in place with one screw in the rear.

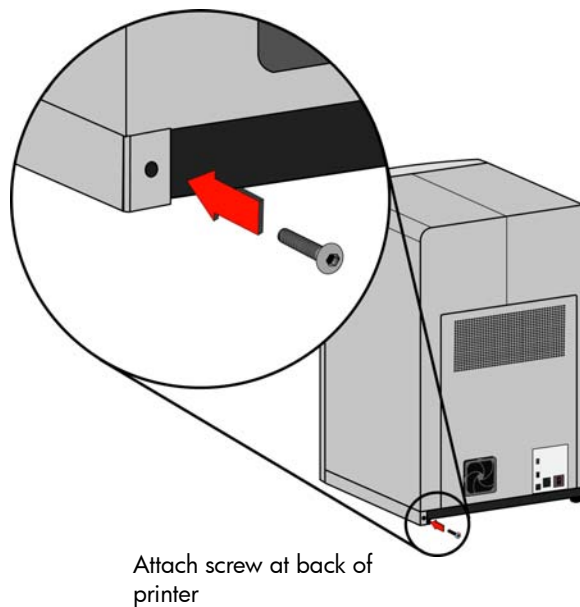
1. Align the left and right side forklift covers with the forklift channel and slide the tabs into the slots. See [Figure 7](#).

**Figure 7** Installing the forklift access covers



2. Push the forklift covers in until they are flush with the back of the printer and install the mounting screws using a  $\frac{1}{8}$ " T handle Allen wrench from the Startup Kit. See [Figure 8](#).

**Figure 8** Installing forklift access cover mounting screws



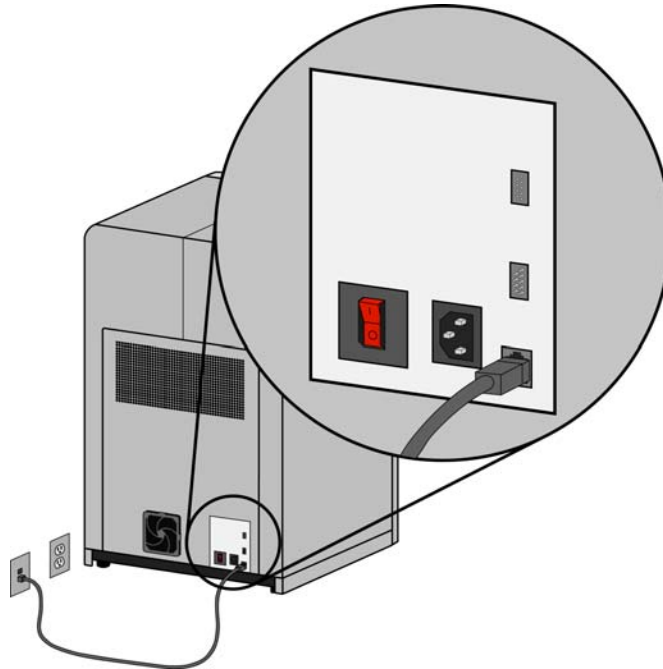
## Networking the printer

There are two methods of connecting your printer to your workstation, over a network or with a direct connection to your workstation.

### Connecting through a network:

1. Locate the network cable (blue) from the startup kit.
2. Connect the network cable between the printer and the network hub. See [Figure 9](#).

**Figure 9** Connecting through a network



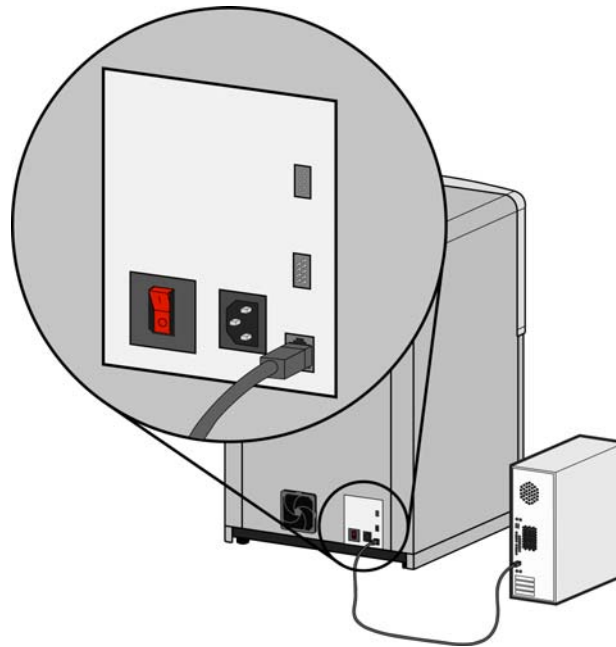
3. Establish communication, see [“Establishing communication on a dynamic network:”](#) on [page 16](#) if you have a dynamic network, or see [“Establishing communication on a static network:”](#) on [page 17](#) if you have a static network.

### Connecting directly to a workstation:

1. Locate the crossover cable (orange) from the startup kit.
2. Connect the crossover cable between the printer and the network port on your workstation. See [Figure 10](#).
3. Establish communication, see [“Establishing communication on a static network:”](#) on [page 17](#)



**Figure 10** Connecting directly to a workstation



## Power Connections

This section discusses the procedure for preparing all power connections for the printer.



**CAUTION:** Before connecting power to the printer, make sure that the circuit breaker is in the off (down) position. It is located at the rear of the printer, next to the power cord attachment point.

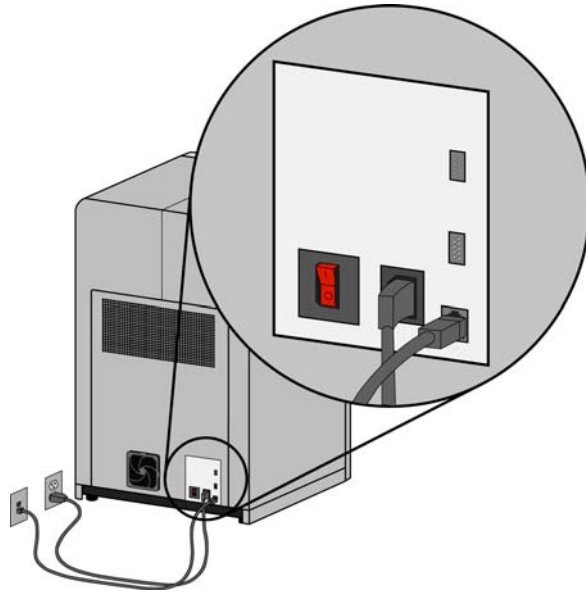
The printer is provided with two power cords: one for 110V (U.S. power cord) and one for 220V (Europe power cord).

1. Connect the male end of the supplied power cord directly into a grounded electrical outlet, as shown in [Figure 11](#). (If using a Uninterrupted Power Supply (UPS), connect the cord directly into the UPS.)
2. Connect the female end of the power cord directly into the rear of the cabinet. See [Figure 11](#).



**CAUTION:** Do not use an extension cord or power strip with the system. Connect the cord directly into the receptacle or UPS.

**Figure 11** Connecting power



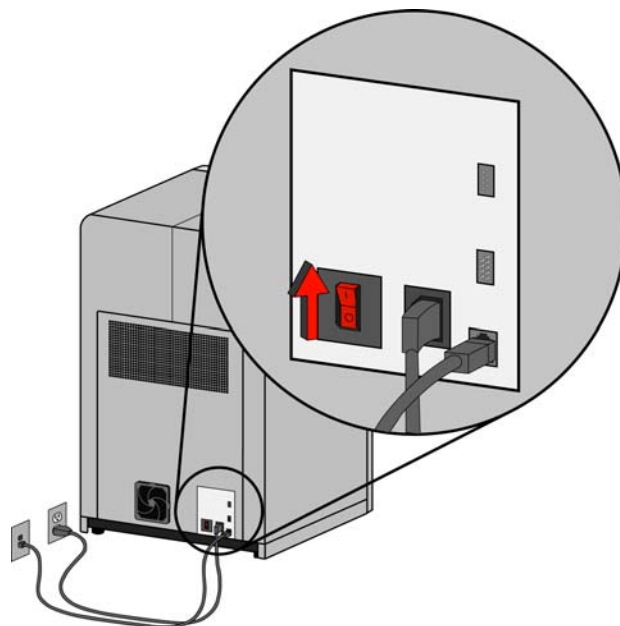
## Powering On



**WARNING:** The build chamber and extrusion-head tip get very hot! The chamber and head tip reach temperatures of approximately 75° C (167° F) and 280° C (536° F) respectively. Personal injury can occur if proper techniques and safety materials are not used. Use the leather safety gloves provided in the Startup Kit when working inside the printer.

1. Switch the circuit breaker to the on (I) position. Power is now supplied to the system. The system is ready to be 'Powered ON'. See [Figure 12](#).

**Figure 12** Location of circuit breaker



2. Turn the power switch to the on (I) position. See [Figure 13](#). After the switch is pushed, the system boots up in three to seven minutes.

---

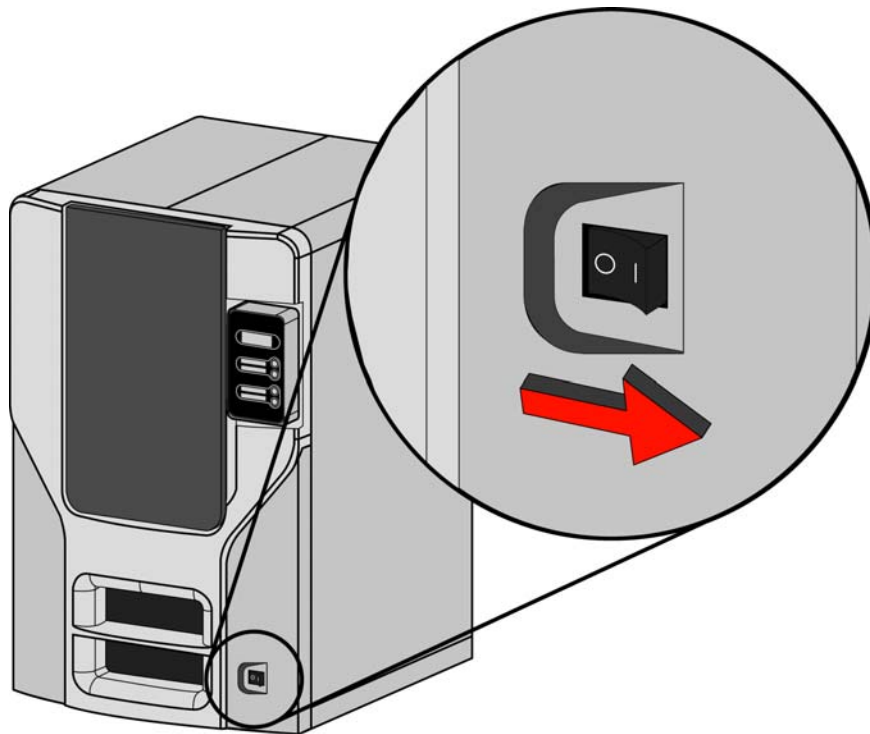
**i** **Note:** If the printer was off and is at room temperature, it requires approximately 40 minutes to warm up before you can perform any functions. Temperatures are factory-preset and not adjustable. The panel displays the head and envelope temperatures while the system is warming up and cooling down.

---

**i** **Note:** For safety, the head and Z Platform do not move while the chamber door is open. During warm-up and operation the door is locked. The door can be opened only when the system is not building a part, getting ready to build a part, or in Pause mode.

---

**Figure 13** Location of power switch



## Installing software

There are two software programs that work with the printer:

1. CatalystEX, installed on your workstation, processes the STL files for printing and communicates with the printer from your workstation.
2. System software, the operating software installed on the printer, controls printer functions.

### Installing CatalystEX:

1. Locate the CatalystEX CD from startup kit and insert into workstation (PC).
2. Click the **Install CatalystEX:** button.
3. Follow prompts to finish loading CatalystEX on the workstation.

## Installing system software to the workstation:

1. Insert the Controller Software CD into the CD drive of your workstation.
2. Click the **Install** button to load system software to your workstation. You will be asked to load this system software to your printer later.
3. Follow prompts to finish installing system software on the workstation.
4. Install system software to the printer, see [“Installing System Software on printer”](#) on page 19

## Establishing network communication with the printer

You will need to establish network communication between your workstation and printer before you can send files to be built. How you establish this communication with an IP address is dependent upon how your network and workstation are configured. If your network is configured for DHCP (Dynamic Host Configuration Protocol), your DHCP server will automatically assign a Dynamic IP address to your printer. This is the default setting for your printer and commonly used in large networks. In some situations you may need to manually enter a Static IP address for your printer and record the IP address in the CatalystEX software. Static IP addresses are frequently used for smaller networks or for direct connection between your workstation and printer. Follow the instructions below to configure your workstation and network.

### Establishing communication on a dynamic network:

If you are on a dynamic network (or not sure of your network type) follow these steps to allow CatalystEX to find your printer and establish communication.

1. Connect a network cable between the printer and a network hub.
2. Make sure the printer is ON and determine the Unique Device Name (UDN) for your printer.
  - a. From **Idle** (or **Ready to Build**), press **Maintenance** on the display panel. The display will show **Maintenance** and the software version.
  - b. From the display panel press **System**.
  - c. From the display panel press **Set Network**. The top window will display: **Network Admin - Dynamic IP Address; UDN**.
  - d. The Unique Device Name (UDN) for your printer is listed here. This is preset at the factory and cannot be changed.
3. From your workstation, start CatalystEX.
4. From the **General** tab, click the **Manage 3D Printers** button.
5. Click the **Add from Network** button in the lower right corner of the window.
6. A new window, **Add 3D Printer**, should list your printer in the main window (identified by its UDN). Click on the printer in this window and enter a name and location in the lower portion of the window.
7. Click **Add Printer** and you are ready to print. Close the **Add 3D Printer** window.



**Note:** If your printer is not displayed in the “Add 3D Printer” window, you are not using a dynamic network and you will need to set up a static network address.

---

## Establishing communication on a static network:

If you are using a static network or connecting the printer directly to a workstation, you will need to enter the static IP address information into the workstation and the printer. If you are using a static network and your computer already has network access, see [“Setting the static network on printer:” on page 18](#)

1. Set the static IP address information in the workstation:
  - a. For Windows Vista, see [“Setting the static network in Windows Vista:” on page 17](#)
  - b. For Windows 7, see [“Setting the static network in Windows 7:” on page 17](#)
2. Set the static IP address information in the printer, see [“Setting the static network on printer:” on page 18](#)
3. Establish communication, see [“Establish communication:” on page 18](#)

### Setting the static network in Windows Vista:

1. From your workstation click on the **Start Menu**.
2. Click on the **Control Panel** button.
3. Double click on **Network and Internet**.
4. Double click on the **Network and Sharing Center** icon.
5. Left click on **Manage network connections**.
6. Right click on the **Local Area Connection** icon then left click on **Properties**.
7. Select **Internet Protocol Version 4 (TCP/IPv4)** from the list.
8. Click on the **Properties** button.
9. Click on the **Use the following IP address** option.
10. Enter the IP address, Subnet Mask and Default Gateway. Contact your IT Administrator or Internet Service Provider for details regarding IP address information. The IP address should be different from the workstation, the default gateway and subnet mask should match the workstation. Enter the IP address, default gateway and subnet mask.
11. Click on the **OK** button when finished. Close any open networking windows.

### Setting the static network in Windows 7:

1. From your workstation click on the **Start Menu**.
2. Click on the **Control Panel** button.
3. Double click on **Network and Internet**.
4. Double click on the **Network and Sharing Center** icon.
5. Double click **Local Area Connection**.
6. Click on the **Properties** button.
7. Select **Internet Protocol Version 4 (TCP/IPv4)** from the list.
8. Click on the **Properties** button.
9. Click on the **Use the following IP address** option.
10. Enter the IP address, Subnet Mask and Default Gateway. Contact your IT Administrator or Internet Service Provider for details regarding IP address information. The IP address should be different from the workstation, the default gateway and subnet mask should match the workstation. Enter the IP address, default gateway and subnet mask.
11. Click on the **OK** button when finished. Close any open networking windows.

### Setting the static network on printer:

1. Obtain your static network address from your Network Administrator.
2. From **Idle** (or **Ready to Build**), press **Maintenance** on the display panel. The display will show **Maintenance** and the software version.
3. Press **System**.
4. Press **Set Network**. The top window displays: **Network Admin - Static IP Address; UDN**.
5. Press **Static IP** to display default settings.

IP Address: 172.016.075.020 or 198.000.000.001  
NM Address: 255.255.000.000  
GW Address: 172.018.100.002



**Note:** These values are the factory defaults and **MUST** be changed. If these values are not changed the printer will continue to restart until they are changed.



**Note:** The IP address should be different from the workstation. The default gateway and subnet mask should match the workstation. Enter the IP address, default gateway and subnet mask.

- 
6. Update the IP address:  
Press **Increment** to increase the value one digit at a time.  
Press **Next Digit** to move the cursor one place to the right.  
Press **Last Digit** to move the cursor one place to the left.
  7. Use the three functions listed above to set your IP address.
  8. After setting the final digit of the Internet Protocol (IP) address, move the cursor one more place to the right. The cursor moves to the Netmask (NM) address. Follow the same steps for setting the Netmask (NM) and Gateway (GW) addresses.
  9. When you have finished setting the addresses, press **Done**. The display will show: **Change IP, Netmask and Gateway?**
  10. Press **Yes**. The panel then displays **Resetting Network**.
  11. Press **Done** until **Idle** is displayed.

### Establish communication:

1. From your workstation, start CatalystEX.
  - a. From the **General** tab, click the **Manage 3D Printers** button.
  - b. Click the **Add from Network** button in the lower right corner of the window.
  - c. A new window, **Add 3D Printer**, should list your printer (identified by its UDN). Click on the printer in this window and enter a name and location of your choice in the lower portion of the window.
  - d. Click **Add Printer** to complete. Close the **Add 3D Printer** window.
2. If your printer is not displayed in the **Add 3D Printer** window, you will need to add the printer IP address manually.
  - a. From the **General** tab, click the **Manage 3D Printers** button.
  - b. Click the **Add Manually** button in the lower right corner of the window.

- c. In the **Add 3D Printer** window, enter a name and location of your choice in the appropriate fields.
- d. Enter the IP Address for your printer in the appropriate field. It will be the same address as entered in step 6.
- e. Select your printer type from the drop down list, either BST 1200es or SST 1200es.



**Note:** If you only have one printer connected, it will be the only printer in the list.

---

- f. Click **Add Printer** and close the **Add 3D Printer** window.
3. If you are unable to connect the printer to your workstation, contact your Network Administrator.

## Installing System Software on printer

1. From the display panel, press **Maintenance**.
2. Press **System**.
3. Press **Load Upgrade**. “Send upgrade from workstation” and the printer IP address will be displayed.
4. From your workstation, open CatalystEX by double clicking on the CatalystEX icon.
5. Click the **Printer Services** tab.
6. Select your printer from the drop down list then click the **Update Software** button.
7. Navigate CatalystEX to the directory where the system software file is located and select the SST1200es.upg file for SST 1200es or BST1200es.upg for BST 1200es. system software will now begin to download to the printer.



**Note:** Default 1200es system software location for 32 bit systems:

**C:\Program Files\Dimension\1200es <version>**

Default 1200es system software location for 64 bit systems:

**C:\Program Files (x86)\Dimension\1200es <version>**

---

8. When system software verification is complete, the printer display will show **Reboot to complete upgrade?** Press **Yes**. The printer will then load the system software then reboot and return to **Idle**.



**Note:** Loading system software will take approximately 10 minutes.

---

## Insert Modeling Base

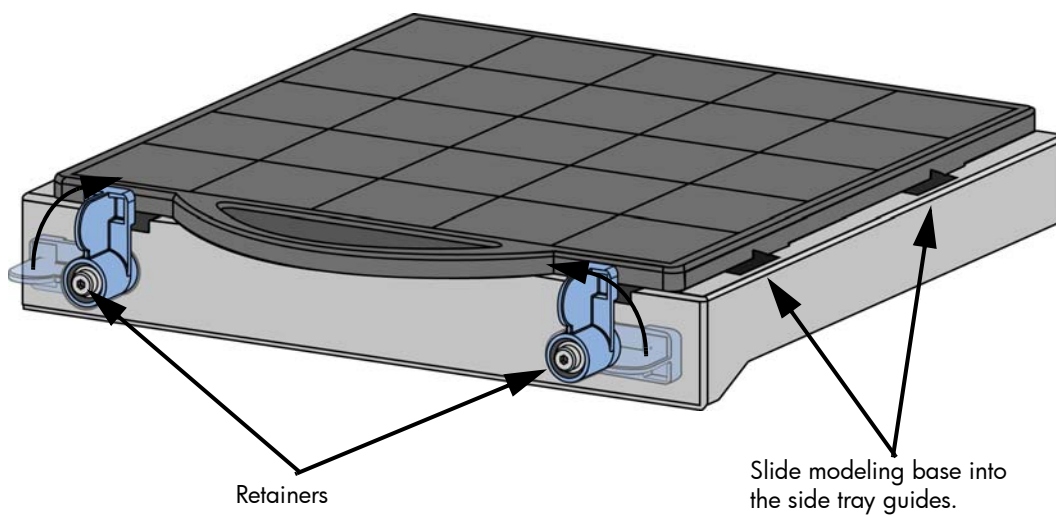
Make sure retainers are turned 'down' - so as not to interfere with the modeling base installation. Set the modeling base on the Z Stage Platen aligning the tabs on the modeling base with the slots on the metal tray. Slide the modeling base toward the back of the unit until its front edge (with the handle) is flush with the front edge of the tray, see [Figure 14](#). Secure the base with the two retainers by turning them up.

---

**i** **Note:** When inserting and removing the modeling base, use the handle to avoid touching the top surface. Grease and oil that contact the top build surface could cause poor part adhesion. You can clean the build surface with isopropyl alcohol if necessary.

---

**Figure 14** Inserting a modeling base





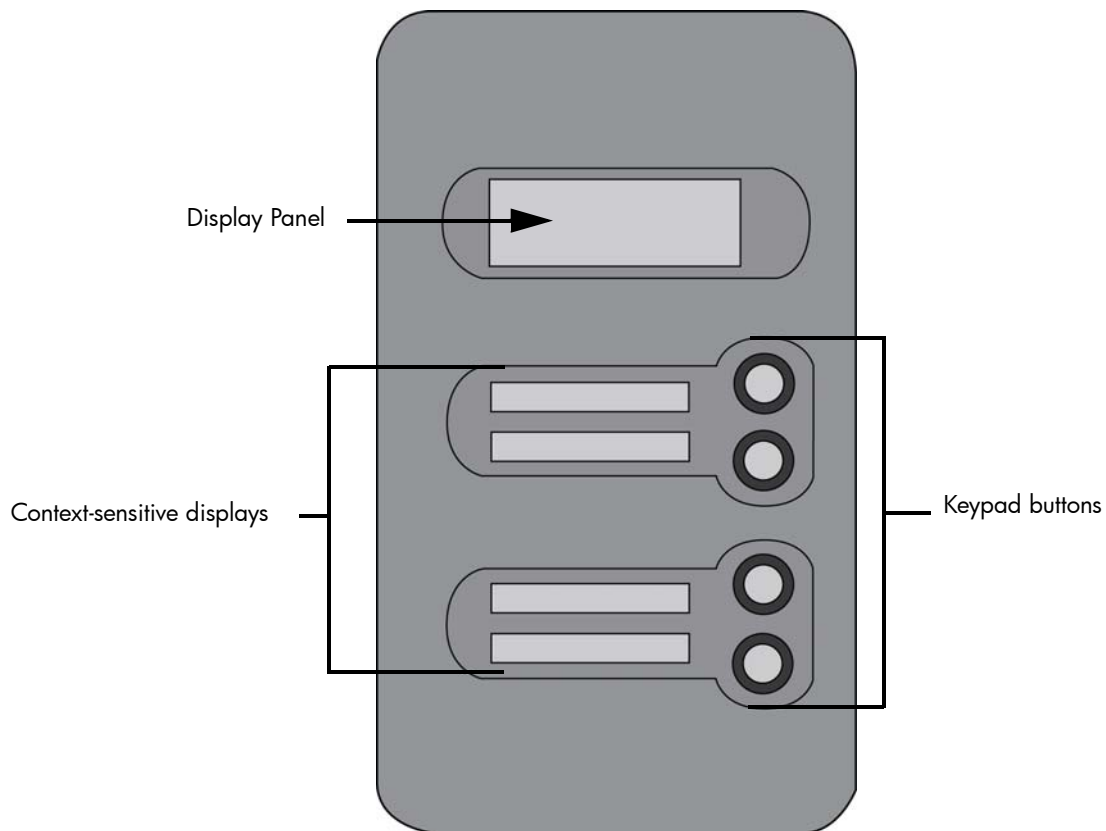
---

# 4 Operation

## Display Panel and Keypad

The main User Interface to the printer is the Display Panel and Keypad, see [Figure 15](#).

**Figure 15: Display panel and keypad**



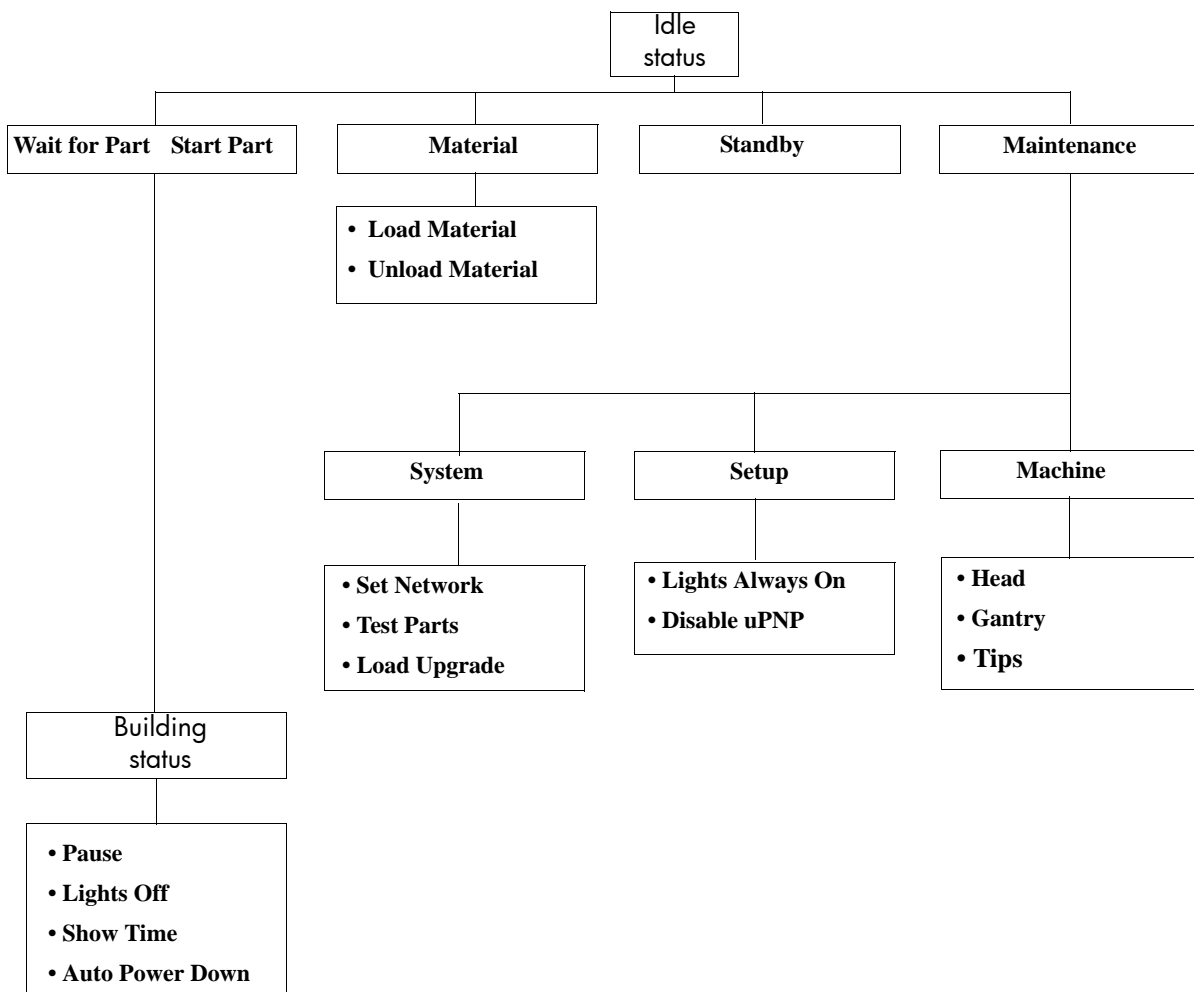
The display panel and keypad are very easy to use, consisting of a larger multiple-line LCD display on top, and four single-line context-sensitive displays, each with one button (or key) below. The top line in the large display always shows printer status. The lower three lines of the large display show details related to the current operation.

At times there will be an item blinking in the lower (context-sensitive) displays. The blinking item is usually the most logical selection.

## System software overview

- **Idle:** If there is no part being built and no part in the build queue, the display will show that the printer is **Idle**.
- **Wait for Part** or **Start Part:** If the printer is in Idle and the build queue is empty, you can set it to wait for a part. If the printer has a part in the build queue, you can press **Start Part** to start a build.
- **Building:** If the printer is building a part, you can choose to pause, set the lights either ON or OFF, view the print time or material remaining and set the printer to auto power down.
- **Material:** From this section you can load material or unload material.
- **Standby:** From this section you can set the printer to Standby mode.
- **Maintenance:** From this section you can make changes to the **System, Setup** or **Machine**.

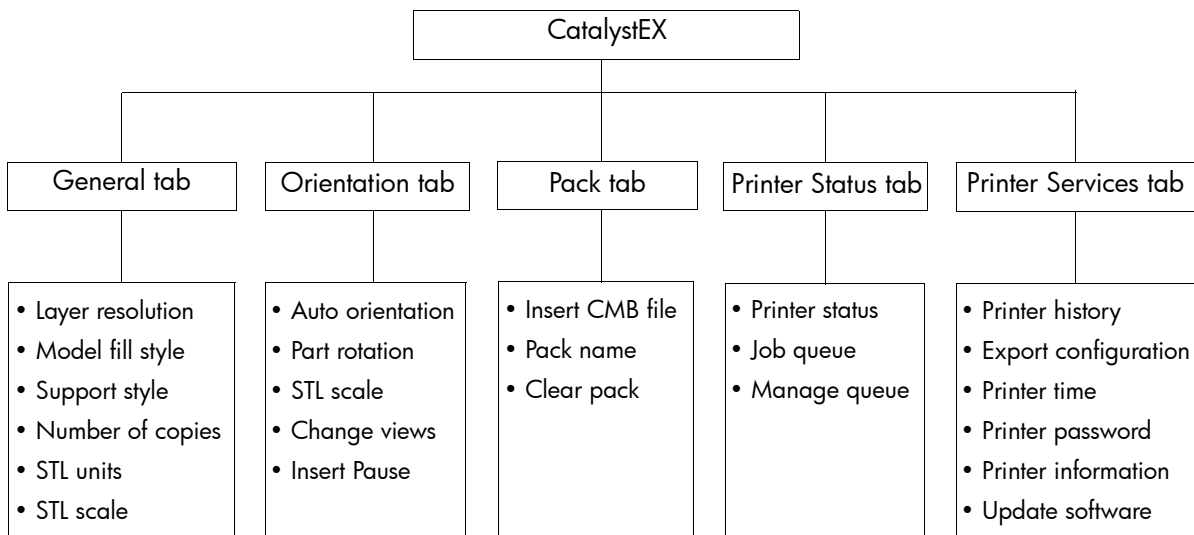
**Figure 16** Display panel hierarchy



## CatalystEX overview

- **General tab:** This section is where you can select the model fill style, support style, change the STL units and STL scale.
- **Orientation tab:** This section allows you to rotate, resize and auto-orient your parts. You can also change the view and insert a pause.
- **Pack tab:** This section shows you which parts are in the pack for printing. You can add parts, arrange the parts for a better fit or clear the pack from this section.
- **Printer Status tab:** This section shows you the amount of material remaining (both model and support) as well as which parts are in the Build Queue.
- **Printer Services tab:** From this section you can check the printer history, set the printer time, set the printer password, update printer software, get printer info and export configuration files (files containing specific operating information regarding the printer).

**Figure 17** CatalystEX hierarchy



**Note:** For detailed information refer to CatalystEX Dynamic Help.

## Processing your STL file for printing

### Opening your STL file with CatalystEX:

1. Create an STL file using your CAD software. Refer to your CAD software help section for more information about converting your CAD drawings into STL files.
2. Open the CatalystEX.
3. From the **File** menu select **Open STL...**
4. Navigate to and select the STL file that you have created.

### Selecting layer resolution:

Layer resolution can be changed on the printer. Changing layer resolution will affect surface finish and build times. Selecting a smaller layer resolution creates a smoother surface finish, but takes longer to build. Layer resolution also affects the minimum wall thickness. Minimum wall thickness applies to the horizontal (XY) plane of your part. If a feature in an STL is smaller than the limit, the modeler will increase the size of the feature to the minimum wall thickness.

Available layer resolutions	Minimum Wall thickness
.010 inch (.254 mm)	.036 inch (.914 mm)
.013 inch (.330 mm)	.047 inch (1.194 mm)

### Selecting model interior fill style:

This establishes the type of fill used for the interior areas of the part. There are three types of model interior that you can choose from.

- **Solid** - Used when a stronger, more durable part is desired. Build times will be longer and more material will be used.
- **Sparse High Density** - This is the default model interior style and is highly recommended. Build times will be shorter, less material will be used and the possibility of part curl for geometries with large mass will be greatly reduced.
- **Sparse Low Density** - The interior will be “honeycombed” or “hatched”. This style allows for the shortest build times and lowest material usage but will decrease the strength of the part.

### Selecting support style:

Support material is used to support the model during the build process. It is removed when the part is complete. Support styles will affect the support strength and build time of the print. SMART support is the default support setting.

- **Basic** - May be used for most parts. Basic support uses a consistent spacing between support toolpaths.
- **SMART** - minimizes the amount of support material used, reduces the build time, and improves support removal for many parts. SMART supports use a wide spacing between toolpath rasters and change the shape of the support region. As the supports descend from the underside of the part feature to the base of the supports, the support region shrinks and transforms to a simpler shape to reduce the amount of material used and the build time. SMART supports are suitable for all parts, especially those with large support regions, and are the default style for builds using soluble supports
- **Surround** - The entire model is surrounded by support material. Typically used for tall, thin models.

## Selecting the scale of your STL file:

Before you process a part for printing, you can change the size of the part within the build envelope. Every part has a pre-defined size within the STL file. After you have opened the file you can change the size of the part produced from the STL file by changing the scale. The scale always relates to the original STL file size definition.

For example: a cube that is defined as 2 X 2 X 2 can be built to be 4 X 4 X 4 by simply changing the scale to 2.0. If after changing the scale to 2.0, you decide that a size of 3 X 3 X 3 would be preferred, change the scale to 1.5 - the scale relates to the original size of 2.0, NOT the resulting 4.0 from the first scale change.

Click within the scale input box to type a scale of your choice.

## Selecting the orientation of your STL file:

The Orientation tab has an expanded preview window. It provides options for viewing a part, measuring a part, orienting a part, processing a part and viewing the layers of a part. How a part is oriented in the preview window will determine how the part is oriented when it prints.

Orientation impacts build speed, part strength, surface finish and material consumption. Orientation can also affect the ability of CatalystEX to repair any problems with the STL file.

You can choose to auto orient your part, which allows CatalystEX to determine the best orientation for the part for the fastest build time and least material usage, or you can manually change the orientation of your part.

Orientation Considerations:

- **Build Speed** - Closely related to material use. A lesser amount of supports will allow for a faster build speed.  
  
Another factor affecting build speed is the axis orientation. The printer can build faster across the X-Y plane than it can along the Z axis. Orienting a part so that it is shorter within the modeling envelope will produce a quicker build.
- **Part Strength** - A model is stronger within a layer than it is across layers. Depending upon what features you want your part to demonstrate, you may need to orient your part to have its greatest strength across a specific area. For example a tab that needs to be pressed would be weakest if you are applying pressure across layers.
- **Surface Finish** - Much like orienting for strength, how the part is oriented will determine how the surface finish will look and allow the printer to provide the smoothest finish for a specific area. For example, if building a cylinder, orienting the cylinder upright will have a smoother surface finish than building it on its side.
- **STL File Repair** - It is possible for an STL file to have errors while appearing to be trouble free. If the STL file contains errors, CatalystEX may have problems processing the file. CatalystEX has the ability to automatically correct some STL file errors. How the part is oriented can impact this automated repair function.

## Adding your STL file to the pack:

The **Add to Pack** button is found on the General, Orientation and Pack tabs.

When you click on the **Add to Pack** button, CatalystEX will add the file that is currently in the preview window (General tab or Orientation tab) to the pack preview window (Pack tab).

If the file in the preview window has not been processed for printing, processing will occur before the file is added to the pack. Each additional click of the **Add to Pack** button will add another copy of the file to the pack.

## Printing your STL file:

The **Print** button is found on the General, Orientation and Pack tabs.

CatalystEX will now process all parts in the pack and create a CMB file from which the printer will print the parts.

## Inserting a Modeling Base

Prior to inserting a modeling base into the tray, remove any material buildup on and behind the Z Platform and around the lead screw. Failure to do so could cause the modeling base to be unlevel or, if the amount of buildup is large enough, the Z Platform could jam at its upper limit.

Install the modeling base. See [“Insert Modeling Base” on page 20](#).



**CAUTION:** DO NOT reuse modeling bases. If a modeling base is reused, calibration errors, poor part quality, and loss of extrusion may occur. Additional modeling bases are available from your reseller.

---

## Building a part

If a part has not been sent to your printer for building, the build queue will be empty. If the build queue is empty the display panel will show **Idle** or **Ready to build**.

Choose whether or not you want to start a build from a remote location or from the display panel at the printer.

### Starting a build from a remote location:

The lower display will show **Wait for Part** and it will be flashing.

1. From the display panel press **Wait for Part**. The display will ask **Is Model Base Installed?**
2. Insert a modeling base.



**CAUTION:** DO NOT reuse modeling bases. If a modeling base is reused, calibration errors, poor part quality, and loss of extrusion may occur. Additional modeling bases are available from your reseller.

---

3. Press **Yes**. **Waiting for Part** will now be on the display.
4. From your CatalystEX workstation, send a part to the printer. The printer will automatically start to build the part. See [“Processing your STL file for printing” on page 24](#) for detailed instructions.

## Starting a build from the display panel:

If **Wait for Part** has not been activated, you can send the part to the printer and start the part from the display panel after the part has been sent to the printer.

1. From your CatalystEX workstation, send a part to the printer. The display will show **Idle/Ready to Build** and the name of the first file that is in the queue waiting to be built.
2. Insert a modeling base.



**CAUTION:** DO NOT reuse modeling bases. If a modeling base is reused, calibration errors, poor part quality, and loss of extrusion may occur. Additional modeling bases are available from your reseller.

---

3. From the display panel press **Start Model** to start building the part.

## Loading Material

Material cartridges are factory packaged in a box and an anti-static, moisture-proof bag to preserve shelf life. Material will stay humidity free inside the cartridge for at least 30 days after opening. Shelf life is more than one year if the cartridge package remains sealed.

### Load material cartridges:

1. Remove packaging.
2. If present, remove the red sealing plug from the cartridge: (see [Figure 18.](#))

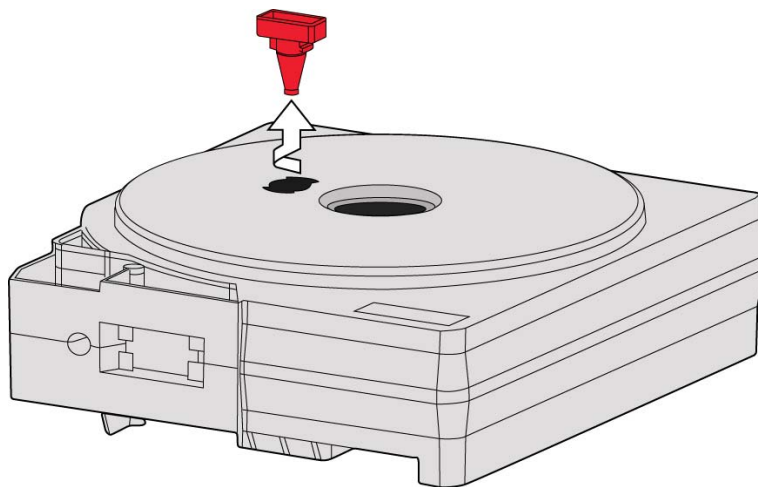


**Note:** Plug must be removed before cartridge can be installed.

---

- a. Turn the plug a quarter turn counter clockwise.
- b. Lift up the plug to remove it from the cartridge - discard (or recycle) the plug.

**Figure 18:** Remove red plug before loading



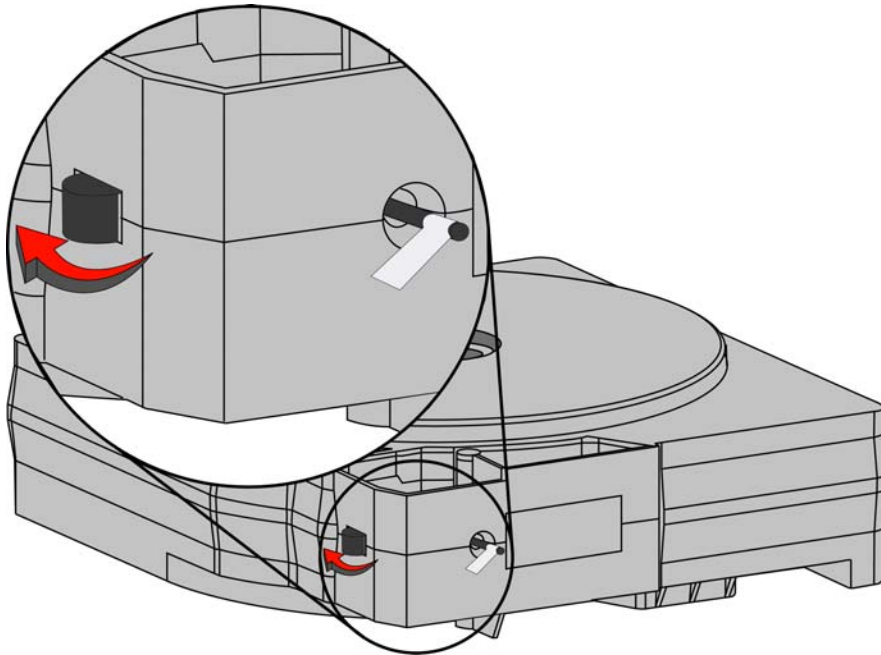
3. Find the end of the material filament taped with a “flag”.



**CAUTION:** Be careful when touching the pinch roller on the side of the cartridge. If you roll it backwards, you could draw the material into the cartridge, see [Figure 19](#). for the correct direction to move the cartridge roller. If this occurs, there is no way to retrieve the filament without opening the cartridge and exposing the material to humidity, which reduces shelf life to a few days.

---

**Figure 19: Direction to move cartridge roller**



4. Pull filament out of cartridge to expose about 12 inches of material. You should easily be able to pull out the material.



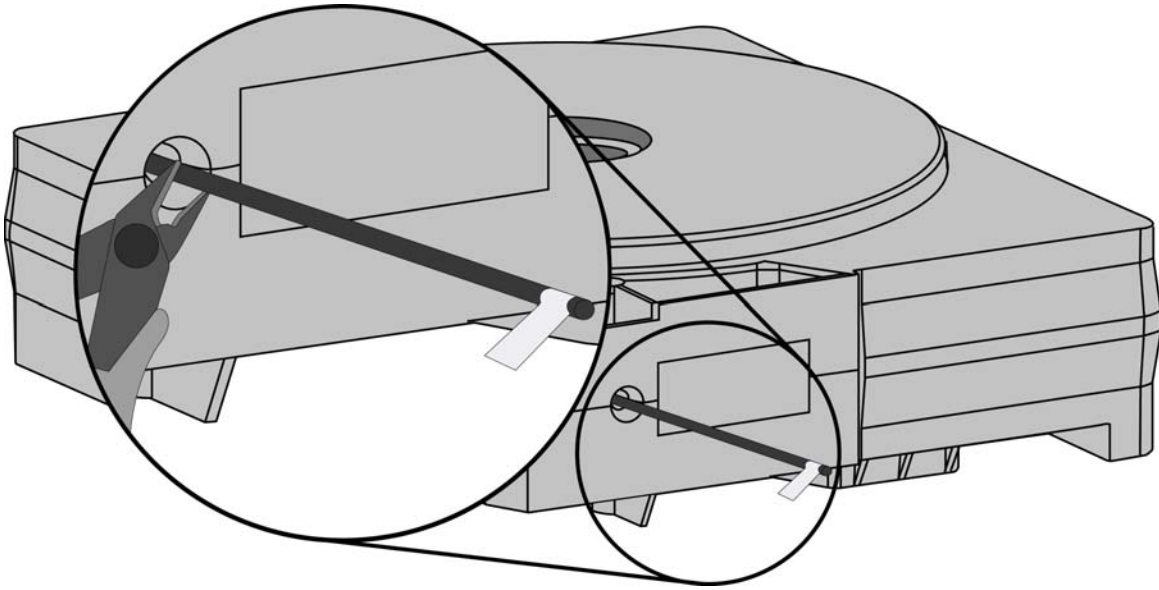
**Note:** The above step makes sure that the filament will feed freely from the spool.

---

5. With the cutter from your Startup Kit, snip the filament flush with the end of the cartridge, see [Figure 20](#).



**Figure 20: Snipping the material filament**



6. If the printer is in **Idle**, press the **Material...** button, which will be blinking.
7. Display will prompt with **Material - Add/Remove** (flashing)
8. Insert material cartridges into their appropriate slot from the front of the printer (Model material cartridge goes in the Top slot; Support material goes in the Bottom slot).
9. When the cartridges have been inserted, press **Load...** (flashing)
10. Display will prompt with **Load Both...**, **Load Model...** or **Load Support...** Press **Load Both...**
11. After material has been loaded to the head press **Done...**

## Unloading Material

The model and support material cartridges may be replaced separately or at the same time. In idle-, load-, or build-related modes, the panel displays the percentage of material remaining in the cartridges. If the printer will be operating unattended for a long period, and the material level is getting low, you may want to replace the cartridges before starting a new part. Of course, you will also need to replace the cartridges when they are empty.

### Unload material cartridges:

1. From **Idle**, press **Material...**
  - a. Press **Unload...**
  - b. The panel displays **Material** and prompts with, **Unload Both...**, **Unload Model...** or **Unload Support...**
  - c. After you have made the above choices, the panel displays **Unloading** for approximately 60 to 75 seconds (the selected materials will be unloaded from the extrusion head).
  - d. When unloading is complete, the panel will prompt you to remove a cartridge based upon your choices - i.e., **Remove Model Cartridge**, **or Remove Support Cartridge**.
2. Remove the material cartridge(s) by first pushing it forward gently, and then pulling it out of the slot.



**CAUTION:** Do NOT try to rewind the filament that remains in the system. This will cause material to cross-wind in the cartridge causing cartridge failure.

- When you remove a cartridge there will be approximately 180 cm (6 feet) of filament that will need to be pulled from the system. (This is normal. Material is only retracted from the extrusion head during 'unloading'.)
3. To store a partially used cartridge, place a small flag of tape on the filament near the cartridge. Cut off and discard the remaining material. The tape flag ensures the filament does not retract into the cartridge.

## Building a Test Part

Factory test parts have been preloaded into your printer. To familiarize yourself with the system, it is recommended that you build one of the test parts before attempting to build one of your own files.

Once the printer has warmed up, material has been loaded, and a modeling base is in place, you can send a test part to the printer.

### Build a test part:

1. Press **Maintenance**.
2. Press **System**.
3. Press **Test Parts**, and select one of the available sample parts.

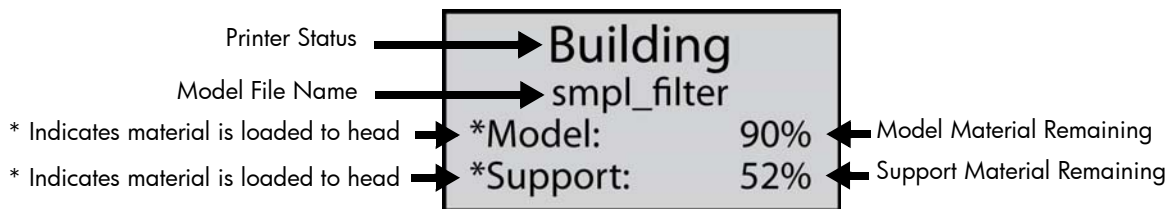
The printer automatically starts building the part.

4. When the part is finished, follow the steps under [“Removing a Completed Part”](#) on page 33.

## The display panel during build

The top two lines of the display panel show printer-status messages, see [Figure 21](#). The bottom line of the panel shows the material amounts remaining in the cartridges.

**Figure 21: Display panel during build**



## Chamber Lights

When a part starts to build, the chamber lights are automatically ON. You can toggle lights ON or OFF through the Display Panel.

You can also turn the light on continuously. Go to the **Idle** or **Ready to Build** mode. Press **Maintenance** and then press **Setup**. Press **Lights Always On**. The light will remain ON until the system is powered OFF.

## Pausing Build

While building a part, you may want to pause the operation - e.g, to allow for replacement of a material cartridge. To pause the build operation at any time, press **Pause**.



**Note:** When the build process is paused, the printer completes the current tool path before pausing.

## Resuming Build from Pause Mode

If you have pressed **Pause**, and are ready to resume building the part, press **Resume**. The printer resumes modeling.

## Resuming Operations from Standby Mode

After several minutes of inactivity, the printer enters Standby mode. During Standby, the head temperature will decrease to save energy.

### Continue operation from Standby mode:

1. Press **Resume**.
  - The panel displays **Ready to Build** and your part's name (if there is a part in the queue). It also shows the amount of material remaining in the model material cartridge and the support material cartridge (e.g. **\*Model 90%**, **\*Support 85%**).
  - **Start Model** begins blinking.
2. Press **Start Model** to begin modeling.  
(The printer may require a few minutes to warm up to proper build temperatures. You can view the temperature values in the display.)

## Canceling a Job

You can cancel a job at any time while the part is building.

### Cancel a job:

1. Press **Pause**.
2. Once the printer stops building, press **Cancel Build**.  
The panel displays **Are you Sure?**
3. Press **Yes**. The panel displays **Build Stopped** followed by the part name.
4. The panel prompts you to remove the part and replace the modeling base. See ["Inserting a Modeling Base" on page 26](#). Once the chamber door has been opened and closed, the panel asks: **Part Removed?**
5. Press **Yes** *only after* removing the part - refer to ["Removing a Completed Part" on page 33](#)".



**CAUTION:** If you press **Yes** before removing the part, the system can be damaged, and a service call will be required.

---

## Auto power down

You can set the printer to automatically power down when a build is complete. This option will save energy usage.

1. While the printer is building, press the **Auto Power Down** button.
2. Turn the power switch, located on the left side of the printer, to the OFF position.

The printer will display **Auto Power Down Mode** and the printer will power down as soon as the build is complete.

### Canceling auto power down:

1. Turn the power switch back to the ON position.

## Powering Off

To power-off Dimension, move the power switch to the OFF position, see [Figure 13 on page 15](#). You can do this at any time without harming the printer. No other steps are necessary. If this is done while the printer is building a part, the current build will be lost. System cooling fans will continue to operate for several minutes. This ensures a safe, systematic power down.



**Note:** For extended non-use periods, unload the material cartridges and then power off the system.

---

## Removing a Completed Part

When the part has completed, the panel displays **Completed Build**, and the file's name. It also shows **Remove Part and Replace Modeling Base**.

### Remove a completed part:

1. Open the modeling chamber door.
2. Release the modeling base retainers and pull the modeling base towards you, out of the tray guides.
3. Insert a new modeling base.
4. Close the modeling chamber door.
5. After you have opened and closed the door, the panel displays **Part Removed?** *only* after removing the part, press **Yes**.



**CAUTION:** The system can be damaged if you answer **Yes** and the part has not been removed!

---

- After you press **Yes**, the panel displays the status as **Ready to Build** for the next part in the queue.

### Remove a completed part from the modeling base:

1. After removing the base from the printer, firmly flex the modeling base back and forth with your hands to loosen the part. For best results, flex the modeling base front-right to back-left.
2. Pull the part off the base.



**Note:** Supports are much easier to remove when the modeling base is still warm.

---

# Removing Support Material

## Breakaway Supports



**WARNING:** Wear safety glasses and LEATHER gloves when removing breakaway supports.

---

Dimension BST 1200es uses breakaway supports. Removing breakaway support is a simple matter of gently removing material by scraping, or twisting. Basic tools such as a pick or needle-nose pliers can facilitate material removal from cavities.

## Soluble Supports



**WARNING:** Wear safety glasses and LEATHER gloves when removing soluble supports.

When removing soluble supports *by hand*, wear LEATHER gloves.

When removing soluble supports *with the soluble concentrate*, wear RUBBER gloves.

---

Dimension SST 1200es uses soluble supports - a water-based solution designed to allow you to simply wash away the support material. Your part is left smooth and clean with the fine details intact. The soluble support material can be removed by hand with relative ease, but is designed to be dissolved off of your parts for hands-free part finishing.

---

# 5 Maintenance

Follow the simple procedures within this chapter to ensure continued proper operation of the printer.

## Startup Kit Tools

The Startup Kit contains replacement parts and a set of tools used to help you maintain the system. The following is a list of the tools contained in the Startup Kit.

- Needle Nose Pliers
- T-Handled Wrench -  $\frac{1}{8}$ "
- T-Handled Wrench -  $\frac{7}{64}$ "
- Leather Insulated Gloves (Pair)
- Cutters
- Brush (bronze)
- Magnifier

## Preventive Maintenance

### Daily

#### Inspect the tip wipe assembly

After each build you should inspect the tip wipe assembly to make sure there is no material build up or wear. If there is material build up or wear, clean the tip wipe assembly. Material build up on the tip wipe assembly can cause part quality issues. See ["Replace the tip wipe assembly"](#) on page 38.

#### Inspect the tip shrouds

After each build you should inspect the tip shrouds for damage or material build up. If there is material build up remove it as needed. If the material will not break free or there is damage to the tip shield, replace the tip shield. See ["Tip shield replacement"](#) on page 40.

#### Remove debris buildup

Remove all material buildup on the Z platform and around the lead screw. Failure to do so could cause the base to not be level or the Z platform to jam at its upper limit.

#### Vacuum build chamber

Vacuum the build chamber to remove all debris and purged material.

## Clean door

The door glass can be cleaned with any commercial glass cleaner.

## Empty the purge container

The plastic purge container is attached to the right side of the modeling envelope rear wall, see [Figure 22](#)

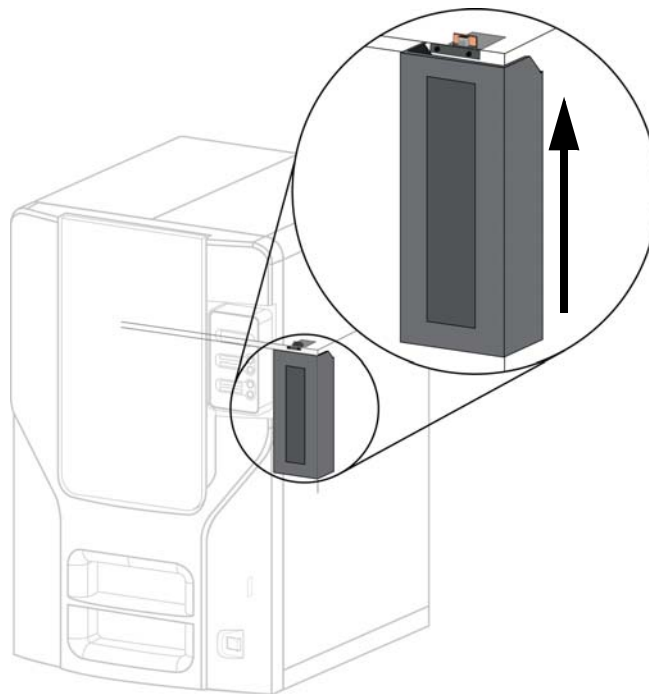


**Note:** A full purge container may impact part quality.

---

1. Remove the purge container by grasping it and pushing it upward to release it from its three mounts. See [Figure 22](#)

**Figure 22: Purge container location**



2. Pull the container towards you and out of the chamber.



**CAUTION:** When reinstalling the container, make sure that it locks on all three mounts and hangs flush with the chamber wall to avoid damage.

---

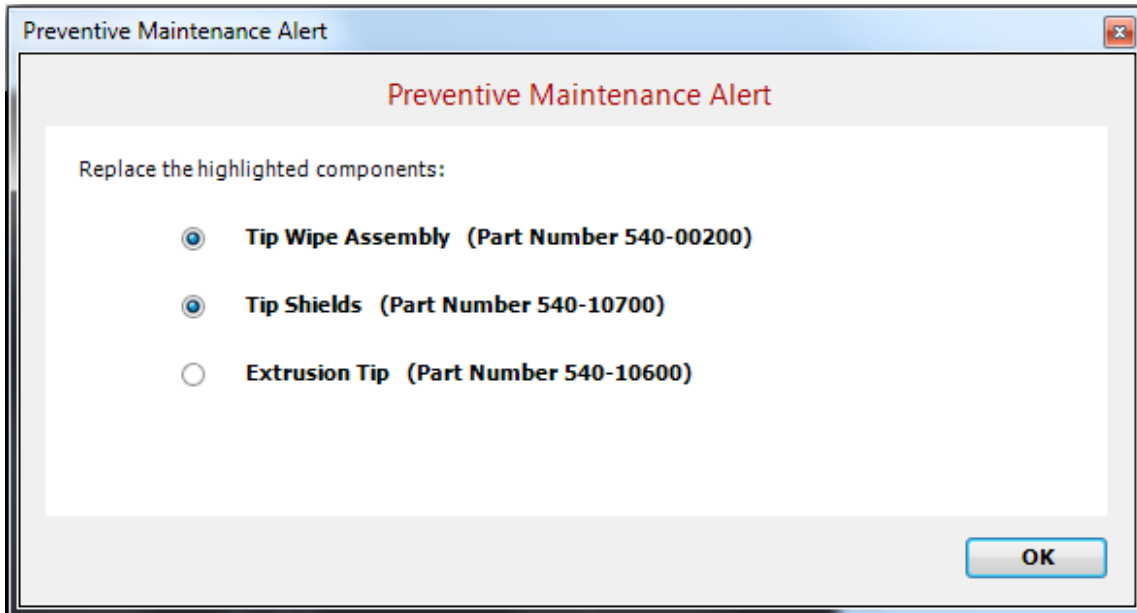
3. Empty the container and reinstall on 3 mounts.



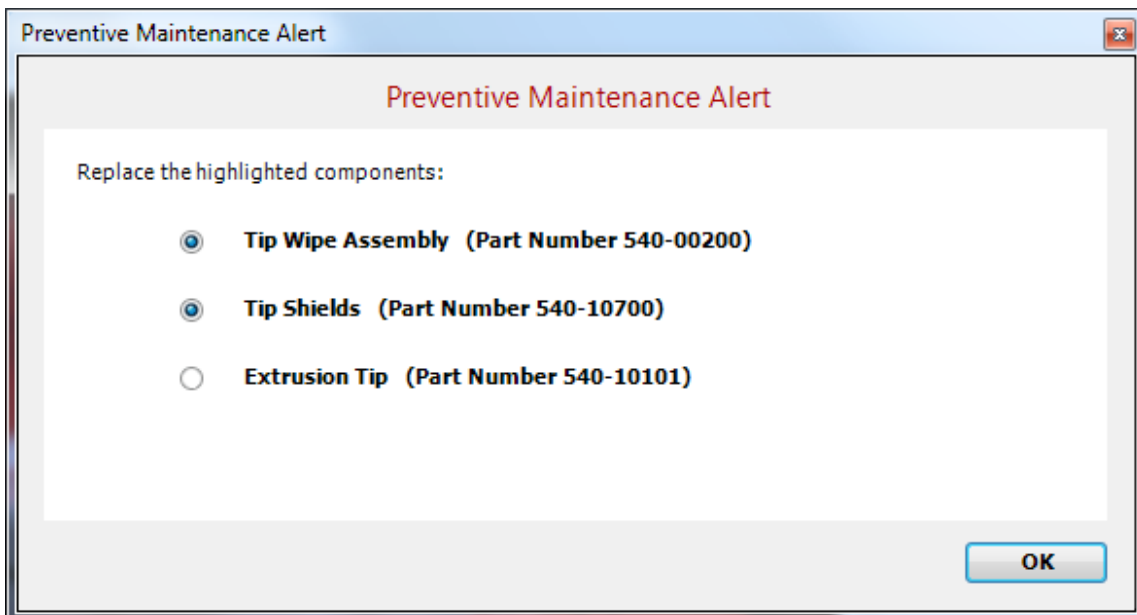
## 500 Hour Maintenance

Preventive Maintenance Alerts will be displayed on the workstation at the 500 hour time interval as a reminder to perform preventive maintenance. See [Figure 23](#) for SST 1200es and [Figure 24](#) for BST 1200es.

**Figure 23** SST 1200es Preventive Maintenance Alert



**Figure 24** BST 1200es Preventive Maintenance Alert

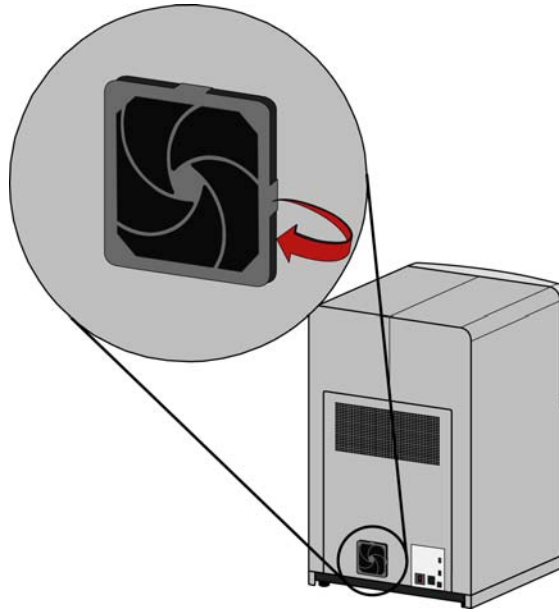


## Clean fan filter

### To clean the fan filter:

1. Locate the lower fan on the rear panel of the printer and remove the plastic frame (snaps on and off) that secures the fan filter. See [Figure 25](#)

**Figure 25: Lower fan location**



2. Clean the filter with soap and water, and blot it dry.
3. Reassemble.

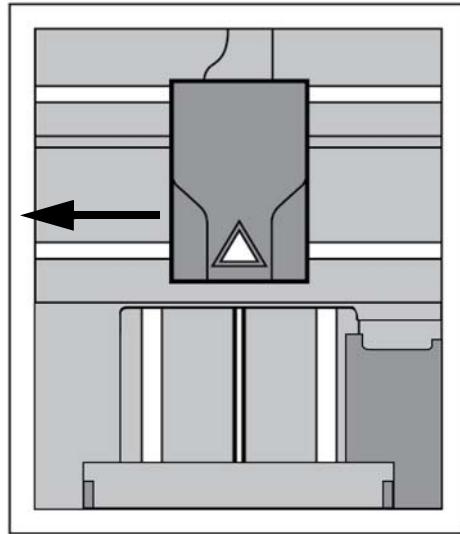
## Replace the tip wipe assembly



**Note:** The tip wipe assembly should be replaced after 500 hours, prior to performing Tip Cleaning Assembly Maintenance.

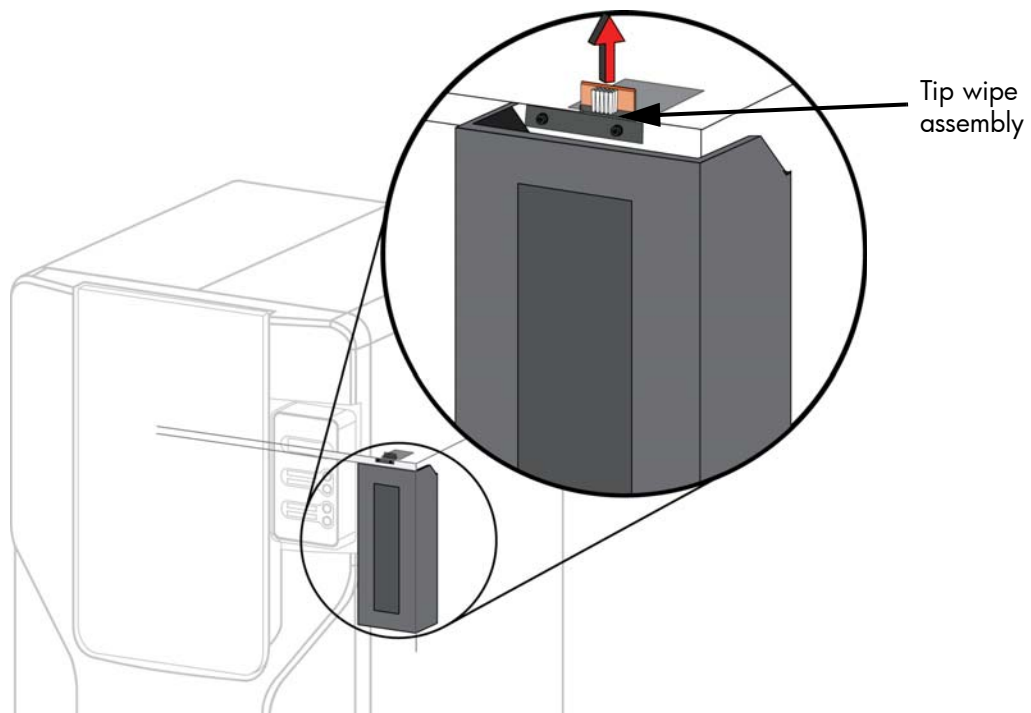
1. Completely power down the printer. See [“Powering Off” on page 33](#).
2. Move the Toggle Head to the left of the machine in order to gain access to the tip wipe assembly, see [Figure 25](#)

**Figure 26: Move the Toggle Head to the left**



3. Remove the tip wipe assembly by lifting the assembly up and out of the machine. Discard the old tip wipe assembly, see [Figure 26](#)

**Figure 27: Replacing the tip wipe assembly**

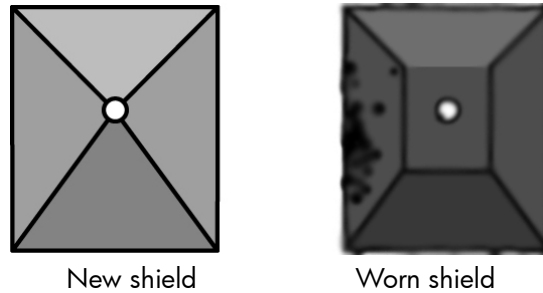


4. Place the new tip wipe assembly over the two mounting posts making sure the assembly is fully seated.

## Tip shield replacement

Tip shields can become torn or damaged over time. This can have a negative impact on the surface finish and detail of models.

**Figure 28: Tip shield damage**



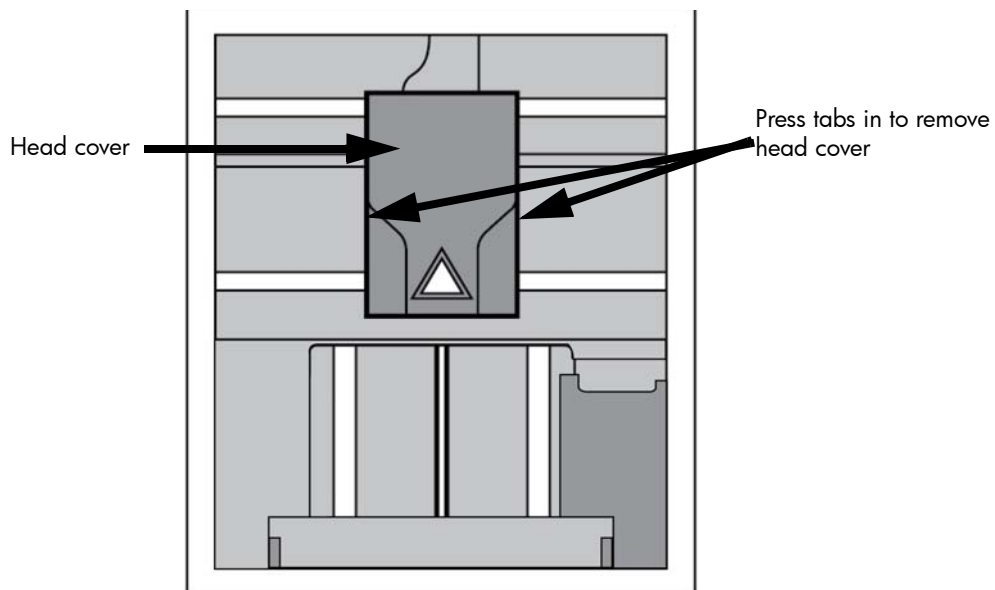
1. Enter **Head Maintenance**.
  - a. From the display panel press **Maintenance**.
  - b. Press **Machine**.
  - c. Press **Head**. The head will come to rest in the center of the chamber and the Z platform will change position.



**Gloves:** The head area is hot, wear gloves when working in this area of the printer.

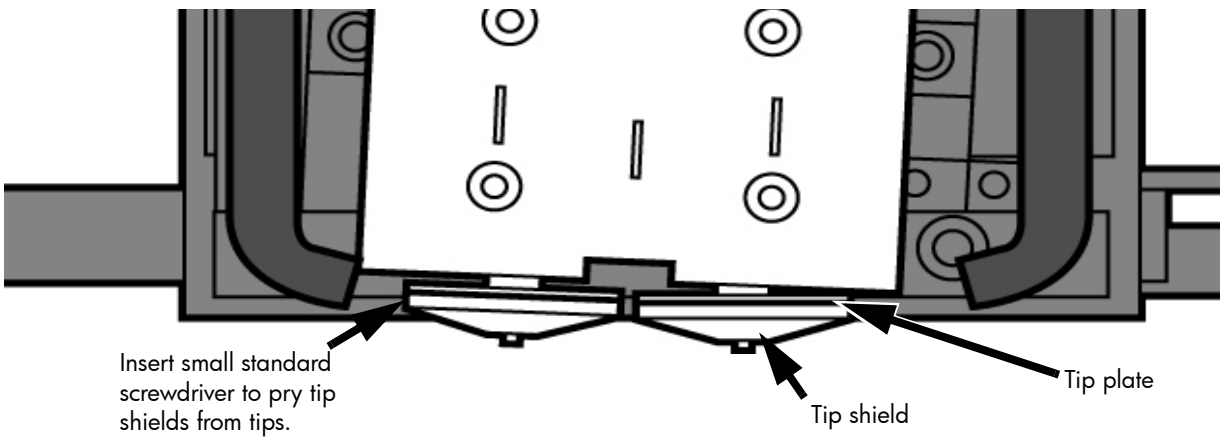
2. Remove the head cover by pressing the tabs in and pulling away from the head. See [Figure 29](#).

**Figure 29 Head cover tab locations**



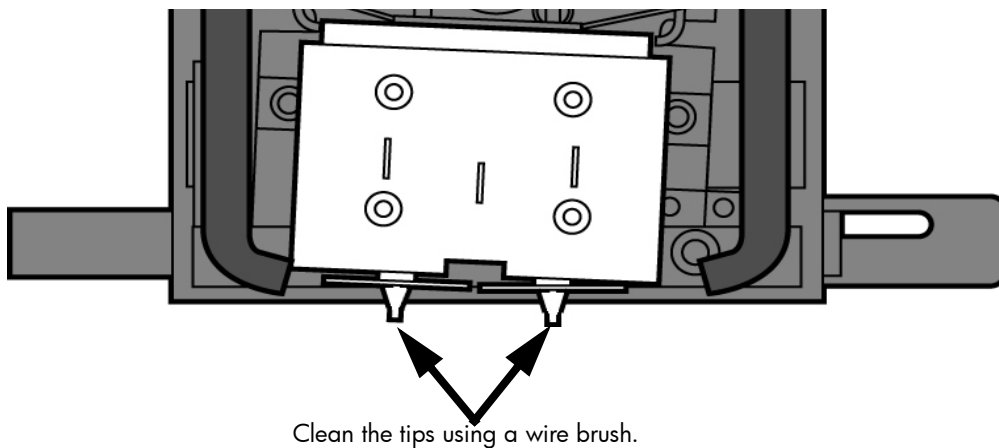
3. Position the blade of a small screwdriver between the tip shield and tip plate. Use the blade of the small screwdriver to separate the tip shroud from the tip plate. See [Figure 30](#).

**Figure 30** Tip shield removal




4. Clean the tip using the wire brush supplied with the Startup Kit to remove any debris. See [Figure 31](#).

**Figure 31** Clean tips with wire brush



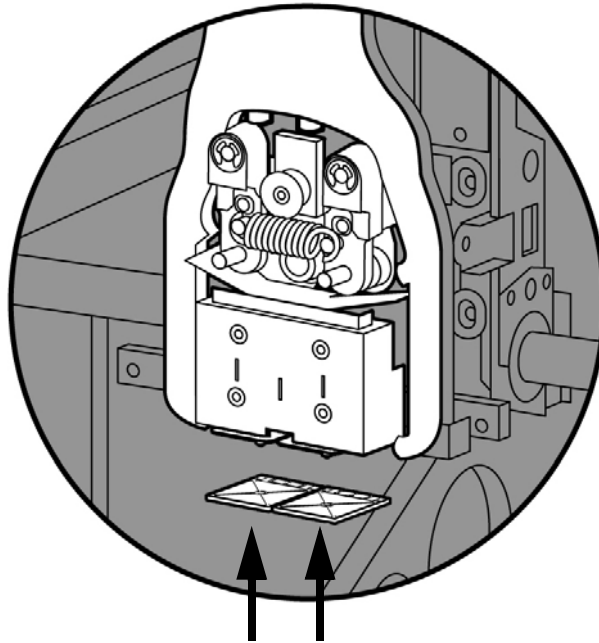
5. Install a new tip shield by pushing it over the exposed tip, keeping the slotted end toward the back of the head. See [Figure 32](#).

---

 **NOTE:** Tip shield should be flush with the tip plate as shown in [Figure 33](#).

---

**Figure 32** Tip shield installation



**Figure 33:** Tip shield placement



Tip shield NOT seated correctly

Tip shield seated correctly

6. Replace head cover.



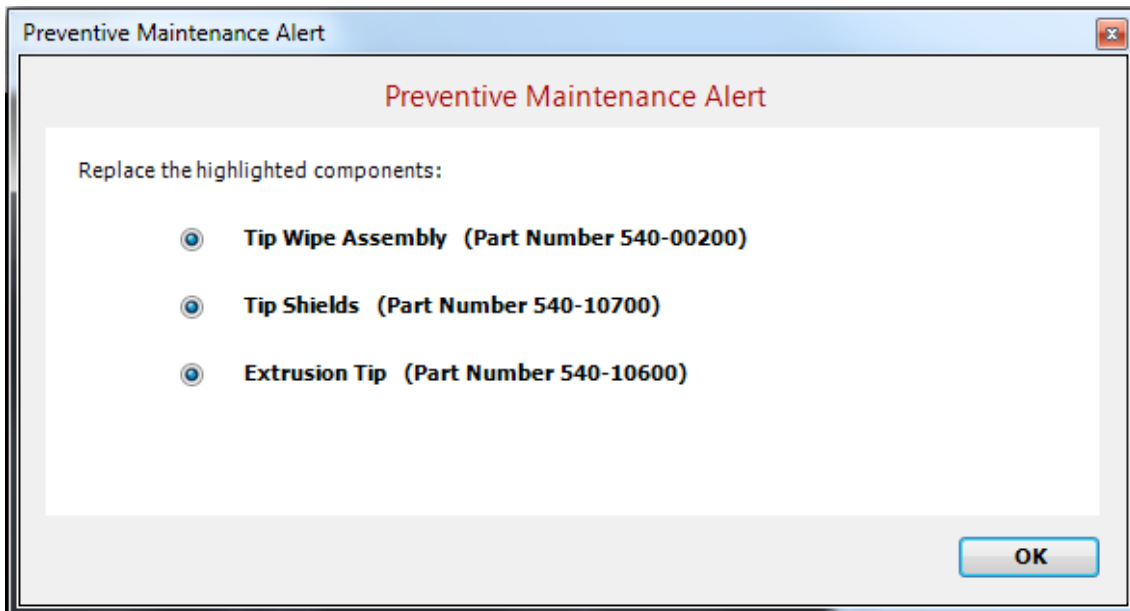
**Note:** If the head cover is not replaced the printer may not function properly.

7. Exit **Maintenance**, press **Done** until back at **Idle**.

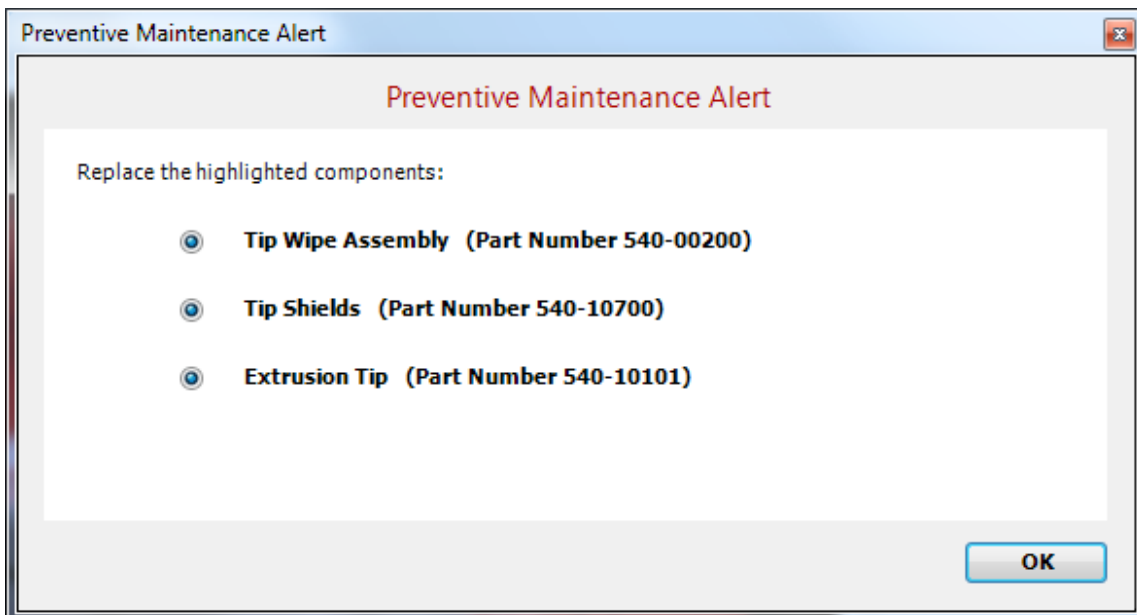
## 2000 Hour Maintenance

Preventive Maintenance Alerts will be displayed on the workstation at the 2000 hour time interval as a reminder to perform preventive maintenance. See [Figure 34](#) for SST 1200es and [Figure 35](#) for BST 1200es.

**Figure 34** SST 1200es Preventive Maintenance Alert



**Figure 35** BST 1200es Preventive Maintenance Alert



## Liquefier Tip Replacement

Replace Tips at approximately 2000 hours - depending upon operating conditions. Tips can also be damaged by improper care while performing maintenance in the area around the tips.

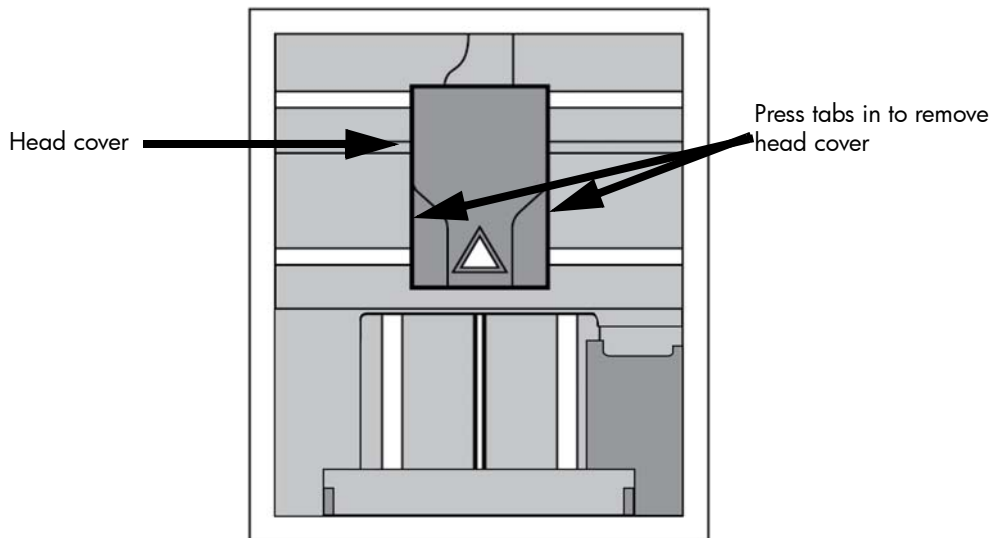


**Note:** CatalystEX displays the tip time (hrs) - from the Printer Services Tab - Printer Info button (Tip time will reset to zero after replacement).

### Removing Tips:

1. You will need to make sure the printer is powered ON before replacing the extrusion tips.
2. From the display panel press **Maintenance**.
3. Press **Machine**.
4. Press **Tip**.
5. Press **Replace**.
6. The printer will display **Material Unload - Unloading Model**.
7. When finished unloading, the display will prompt to remove the material cartridges. Push the material cartridges in and release to unlatch.
8. You can now open the printer door and replace the tips - or you can **Cancel** the tip replacement procedure.
9. Remove plastic head cover by squeezing raised pads on sides of cover. See [Figure 36](#)

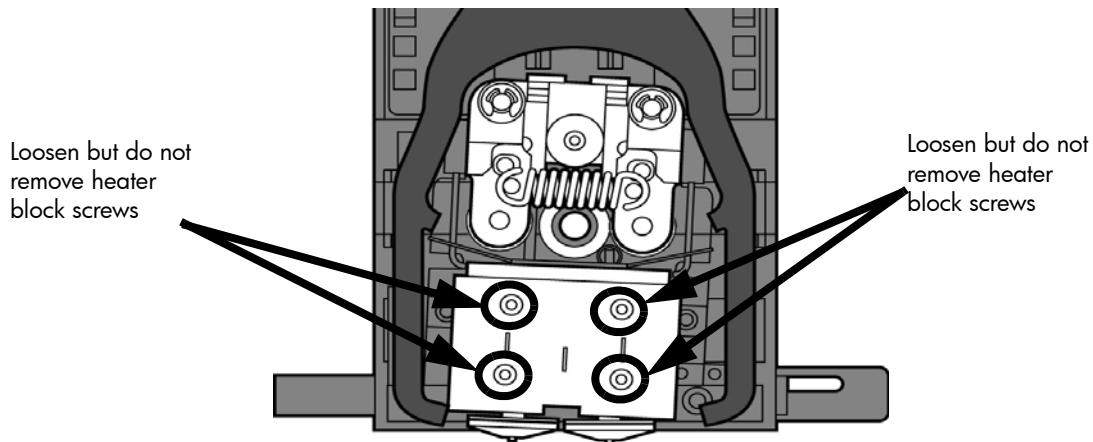
**Figure 36: Removing the Head Cover**



10. Remove Tips:
  - a. Use  $\frac{7}{64}$ " T-Handle Allen wrench to loosen the heater block screws three to four full turns counterclockwise - or until the top of the screws are flush with the metal cover. DO NOT remove the screws entirely. See [Figure 37](#)

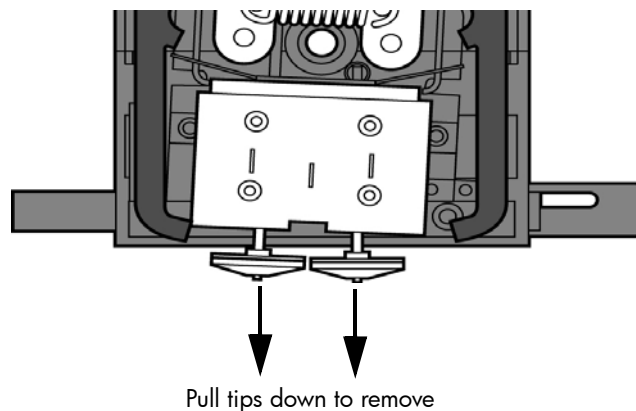


**Figure 37** Tip removal



- b.** Use needle nose pliers to grasp the stainless steel shield of the tip.
- c.** Pull the tip shield toward you, then pull down to remove the tip from the heater block. Discard the used tip. See [Figure 38](#)

**Figure 38** Remove the tips



- d.** Repeat for second tip if necessary.

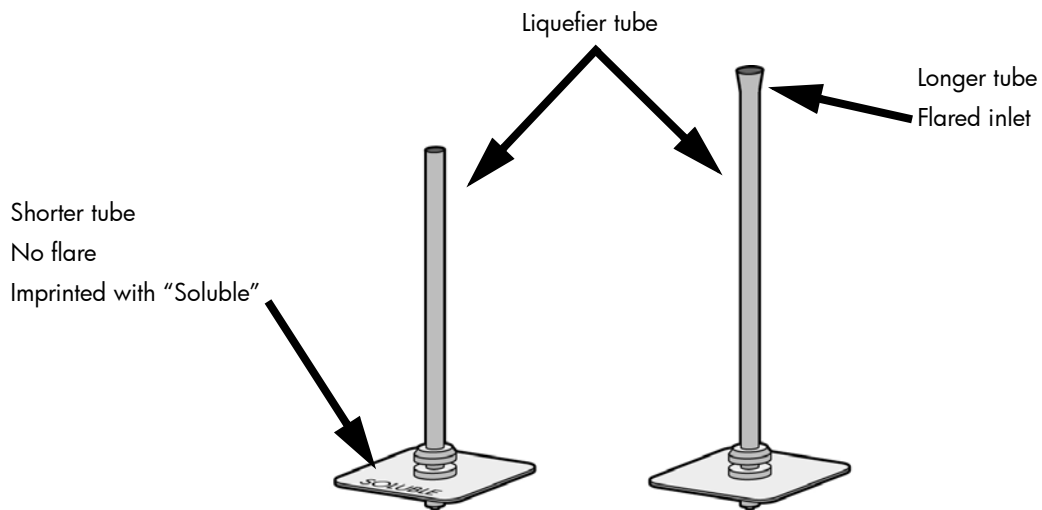
### Installing Tips:

- 1.** For a Dimension BST1200es, the SUPPORT tip and MODEL tip are interchangeable. Both tips are the same as the MODEL tip shown in [Figure 39](#) (The tips come in a Red capped container).
- 2.** For a Dimension SST 1200es, you must identify the correct replacement tip. The SST 1200es uses two tip types. You must make sure a SUPPORT tip is used on the LEFT side of the head assembly. A MODEL tip must be used on the RIGHT side of the head assembly (See [Figure 39](#)). The Model tip comes in a red capped container. The Support tip comes in a black capped container.



**CAUTION:** For a Dimension SST 1200es: Model and SOLUBLE support tips are different. The correct tip must be installed in the correct side.

**Figure 39: Identifying Tips**

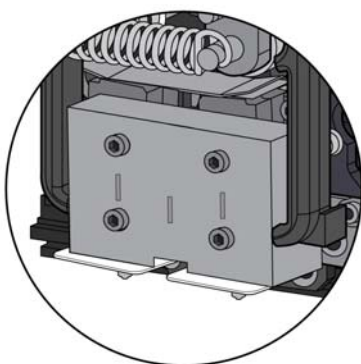


3. With gloved hand, insert the new tip into the heater block.
4. Use needle nose pliers to grasp the stainless steel shield of the tip.
5. Pull the tip shield toward you, then lift up to install the tip.
6. Push the tip toward the back of the printer once it is all the way up against the heater block.
7. Verify the tip is fully inserted into the heater block and that the stainless steel shield is aligned, see [Figure 40](#)
8. Use  $\frac{7}{64}$ " T-Handle Allen wrench to firmly tighten the heater block clamp screws.

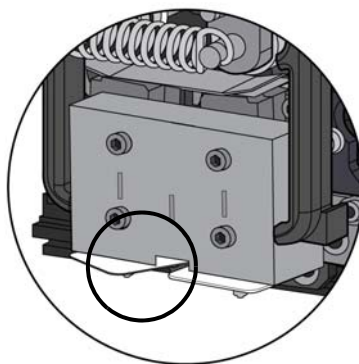


**Note:** Make sure Tip remains all the way up against the heater block as you tighten the screws.

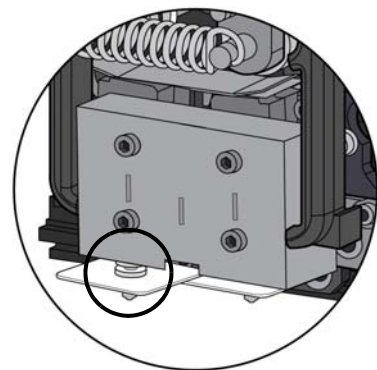
**Figure 40: Installation Examples**



CORRECT



INCORRECT -  
Shield interference




INCORRECT -  
Tip not seated

9. Repeat steps 3 through 8 for second tip if necessary.

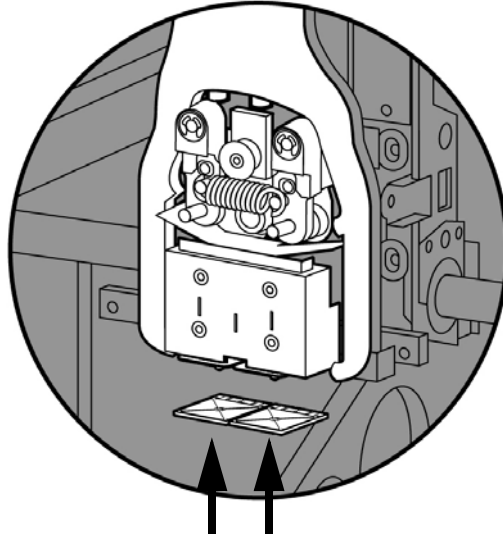
10. Install a new tip shield by pushing it over the exposed tip, keeping the slotted end toward the back of the head. See [Figure 41](#)

---

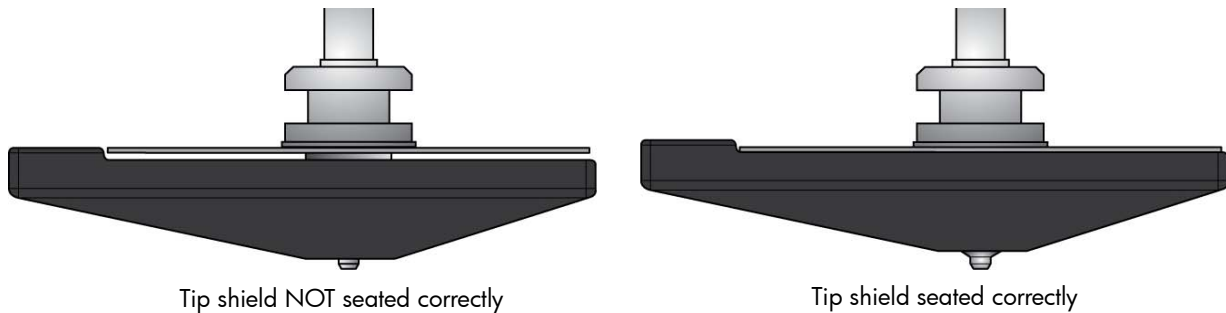
 **NOTE:** Tip shield should be flush with the tip plate as shown in [Figure 42](#).

---

**Figure 41: Tip shield installation**



**Figure 42: Tip shield placement**



11. Replace Plastic Head Cover and close the printer door.

---

 **Note:** If the head cover is not replaced the system may not function properly.

---

12. The printer will display **Tip Maintenance - Tips Replaced?** - select **Yes** to begin material load.
  - a. The printer will display **Maintenance - Add/Remove** (flashing).
    - If you want to replace a material cartridge, do so now.
  - b. Load the model and support material cartridges by pushing in until they latch. Press the **Load Selected** button.
  - c. The printer will now begin to load material. See [“Loading Material” on page 27](#).

- d. After Material Loading is complete the printer will display **Tip Calibration - Install Modeling Base And Build Calibration Part.**



**CAUTION:** Make sure a NEW, UNUSED modeling base is installed before starting calibration. Calibration results will be incorrect if a NEW, UNUSED modeling base is not used.

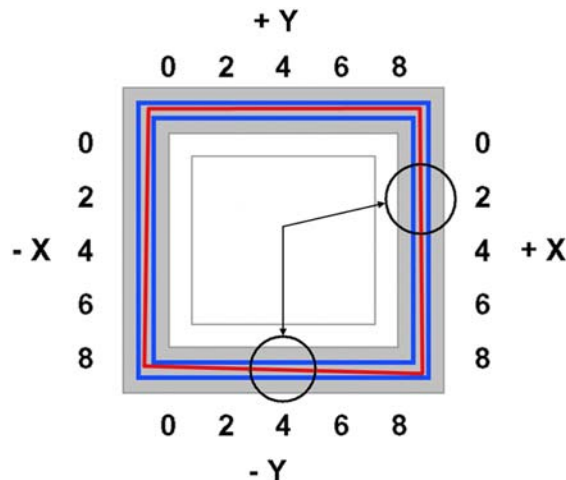
### Tip calibration:

Tip replacement requires Tip Calibration.

1. Select **Start Part** (flashing) - the printer will run two calibration parts.
  - The printer will automatically build a Z Calibration part, measure the part and calibrate the Z Axis for tip depth and tip level (approximately 5 minutes). The Z calibration is automatic.
  - The printer will then automatically build an XY Calibration part (approximately 10 minutes). You must inspect the XY Calibration part and calibrate the X and Y axis for tip offset:
2. When the XY Calibration part is complete the printer will display **Remove Part and Select XY Adjustment - X:0, Y:0**
3. Remove the XY tip calibration part from the printer.
4. Inspect the part and calibrate the X and Y axis, See [Figure 43](#).
  - a. Use the magnifier from the Startup kit to view the support road (shown in red).
  - b. Identify the location on the +X or -X side of the part where the support road is best centered within the model boundaries (shown in blue).
  - c. Read the number closest to this location. This is the required X Tip Offset adjustment. If the number is on the -X side, a negative offset is required.
  - d. Select **Increment** or **Decrement** to input the X offset adjustment - the value will change in the upper display window (by default, the printer will be ready to accept the X value).
  - e. When you are satisfied with your X offset value, **Select Y** and repeat steps A- D to identify and input the required Y Tip Offset adjustment.

**Figure 43** Example XY Tip Offset Part.

This example requires an adjustment of  $X = + 2, Y = - 4$



5. Select **Done** after you have input the X and Y offsets. The printer will return to **Maintenance**. Run the XY calibration a second time to be sure the values changed the offset properly.
6. When finished, press **Done** until back at **Idle**.

## As Needed Maintenance

The following maintenance items have no routine schedule but should be tended to as needed.

### Chamber Light Bar



**ESD:** Use proper ESD grounding techniques when handling electronic components.

---



**CAUTION:** Use only a factory authorized replacement light bar.

---

Replace a chamber light bar when it burns out.



**Note:** There are two light bars in the modeling chamber. They are located on the front wall of the chamber - one to the right, the other to the left of the chamber door.

---

#### Replace chamber light bar:

1. Power down the printer.
2. Locate the wiring harness leading away from the bottom of the light bar.
3. Disconnect the light bar from the wiring harness by squeezing the wiring harness clip while pulling down.
4. Remove the light bar by removing the 3 attachment screws (top, middle, bottom) - use the  $\frac{7}{64}$ " T-handle wrench supplied in the Startup Kit.
5. Install a replacement light bar with the 3 attachment screws - do not overtighten the screws.
6. Re-attach the wiring harness lead.

---

# 6 Troubleshooting

## Troubleshooting Checklist

Problem or error message	Solution
No power	<ol style="list-style-type: none"><li>1. Verify power cord is securely plugged in.</li><li>2. Verify that the circuit breaker (at rear of system) and the power switch (on front panel of system) are both in the ON position.</li><li>3. Verify AC power is present at wall outlet.</li></ol>
System fails to reach operating temperatures	Verify the system is not connected to an extension cord or power strip.
Material not extruding	Filament may be jammed in extrusion head, see <a href="#">“Recovering from loss of extrusion” on page 56</a> .
Model/Support Jam in head clear before resuming	See <a href="#">“Material Jam” on page 54</a> .
Purge material accumulating on part.	<ol style="list-style-type: none"><li>1. Make sure that the flicker and brush are set to the proper height. See <a href="#">“Replace the tip wipe assembly” on page 38</a>.</li><li>2. Check condition of Flicker and Brush. Replace if worn. See <a href="#">“Replace the tip wipe assembly” on page 38</a>.</li></ol>
No text displayed on Display Panel	Cycle power (see <a href="#">“Cycling power” on page 52</a> ).
Cannot communicate with system through network	<ol style="list-style-type: none"><li>1. Make sure network cables are connected - at the printer, at the PC, and where cables connect to network boxes.</li><li>2. Re-configure settings per, see <a href="#">“Networking the printer” on page 12</a>.</li><li>3. If using a Static network address, verify that the IP address entered in CatalystEX has the same value as the address entered for the printer.</li><li>4. Your system configuration may have changed. Contact your Network Administrator.</li></ol>
Error Code displayed on Display Panel	Call your local reseller for customer service. For more information, refer to <a href="#">“Fault determination codes” on page 51</a> .
Display Panel displays <b>Build Error</b>	Partial or bad part file sent to system. Check STL file validity in CAD software; reprocess STL in CatalystEX and re-download to system.

<b>Problem or error message</b>	<b>Solution</b>
Display Panel displays <b>Can't Find Home – Check Modeling Base</b>	<ol style="list-style-type: none"> <li>1. Verify a modeling base is inserted.</li> <li>2. Modeling base may be used or defective – replace.</li> </ol>
Display Panel displays <b>Communication lost at HR:MN UCT</b>	The system stopped reporting its status at the Universal Coordinated Time (UCT) shown. Wait for the system to complete building the part. The system will automatically restart and display Build Complete. It is then safe to remove the model.
Display Panel displays <b>Could Not Read Cartridge</b>	<ol style="list-style-type: none"> <li>1. Remove cartridge and cycle power, see <a href="#">“Cycling power” on page 52</a>; reload cartridge.</li> <li>2. Try a different cartridge.</li> </ol>
Display Panel displays <b>Load Failed</b>	<ol style="list-style-type: none"> <li>1. Retry with same cartridge.</li> <li>2. Try a different cartridge.</li> <li>3. Filament may be jammed in extrusion head, see <a href="#">“Diagnosing loss of extrusion” on page 52</a>.</li> </ol>

## Fault determination codes

If a fault occurs which would prevent the printer from executing an operator request, the printer will begin to shut down and cool. The panel will display an error code. An error-code list (with the filename “error.txt”) can be found on the CD-ROM for the printer system software. (Because this list may change with each new software version, be sure to check the error.txt attachment when you install new system software upgrades.)

After the printer has finished cooling, the only option displayed is **Continue**. Press **Continue** and the printer will reboot and try to return to normal operation. If pressing **Continue** does not eliminate the error, power should be cycled (see [“Cycling power” on page 52](#).); wait 60 seconds before switching power on again. In most cases you will be able to continue operation. However, if the printer continues to shut down and display the same error, contact technical support.

## Exporting printer configuration (.cfg) file

If your printer is receiving fault determination codes, you may need to export a configuration (.cfg) file from your printer to send to Customer Support.

### Exporting configuration file from printer:

1. Open CatalystEX from your workstation.
2. Click on the **Printer Services** tab.
3. Click on the **Export Configuration** button.
4. Browse to the directory where you wish to save the configuration file.
5. Click on the **Save** button.
6. Close CatalystEX.

## Cycling power

1. Turn the power switch to the OFF position. The display will show **Shutting Down**.
2. After the printer has cooled down enough to shut down, the display will go blank.
3. When the display is blank and the printer has shut down, turn the circuit breaker to the OFF position.
4. Once the circuit breaker has been turned to the OFF position, wait 60 seconds and turn the circuit breaker back to the ON position.
5. Turn the power switch to the ON position. The printer display will show that it is starting up.

Once the display shows **Idle** or **Ready to Print**, you can send a file to the printer to be printed.

## Diagnosing loss of extrusion

Occasionally, the printer's head may experience loss of extrusion. This will be evident by observing one of the following:

- The head is moving with no material coming out of either tip.
- The height of the model and support materials are not equal.
- Sagging structures due to lack of support materials.



**Gloves:** The head area is hot. Use gloves when working in this area of printer.

---

1. From the display panel press **Cancel** and remove parts from the printer.
2. Insert a new modeling base.
3. From **Idle**, press **Maintenance**.
4. Press **Machine**.
5. Press **Head**. The head will move to the center of the chamber and the Z platform will change position. The display will read: **Model Drive Motor Stopped**.
6. Determine if there is a model material extrusion problem by pressing **Forward** (command will be available after head reaches operating temperature). Watch the model tip (right tip) for any extrusion (material purge).



**Note:** You may need to wait up to 30 seconds before extrusion will begin as the tip may need to reach operating temperature.

---

7. Press **Stop** to stop the extrusion.
8. If material did NOT flow from the model tip, see ["Recovering from loss of extrusion" on page 56](#). If material steadily flowed from the model tip, the model tip is functioning properly.
9. Test the support material tip by choosing: **Select Drive**.
10. Determine if there is a support material extrusion problem by pressing **Forward**. Watch the support tip (left tip) for any extrusion (material purge).
11. Press **Stop** to stop the extrusion.
12. If material did NOT flow from the support tip, see ["Recovering from loss of extrusion" on page 56](#). If material steadily flowed from the support tip, the support tip is functioning properly.
13. Return the system to the Maintenance state - Press **Done**.



14. Display will ask **Which Materials Loaded?** Press **Both**.
15. Press **Done** until back at **Idle**.

## Clogged tip

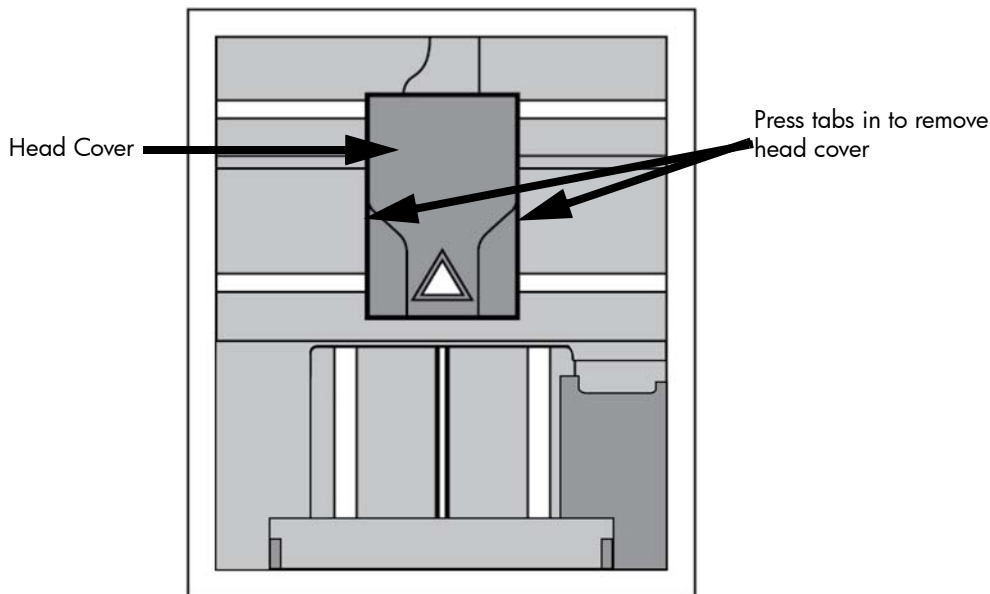
Occasionally, a tip may clog with material. This will often result in a loss of extrusion (LOE). A clogged tip will prohibit material load and part building.

1. Remove the head cover by pressing the tabs in and pulling away from the head. See [Figure 44](#).



**Gloves:** The head area is hot. Use leather gloves when working in this area of printer.

**Figure 44: Remove the head cover**



2. Inspect top of tips for material build up. If there is excess material build up see [“Recovering from loss of extrusion” on page 56](#). If there is no excess material build up close the chamber door and continue.
3. From the display panel press **Maintenance**.
4. Press **Machine**. The printer will calibrate which will take approximately 3 minutes.
5. Press **Head**. The head will heat up to operating temperature which will take approximately 3 minutes.
6. Press **Select Drive** and choose the drive that may have the clogged tip.
7. Press **Forward**, the drive wheel will turn the selected drive forward.
8. Press **Blower Off**, this will turn the head cooling fan off for 10 seconds, allowing the tip to heat up beyond operating temperature. If material starts to extrude the tip is no longer clogged. If material does not extrude see [“Recovering from loss of extrusion” on page 56](#)
9. Press **Done**.

10. Replace head cover.



**Note:** If the head cover is not replaced the printer may not function properly.

11. Display will ask **Which Materials Loaded?** Press **Model** if only model material is loaded, press **Support** if only support material is loaded or press **Both** if both model and support material are still loaded. Press **None** if neither are loaded.
12. Press **Done** until back to **Idle**.

## Material Jam

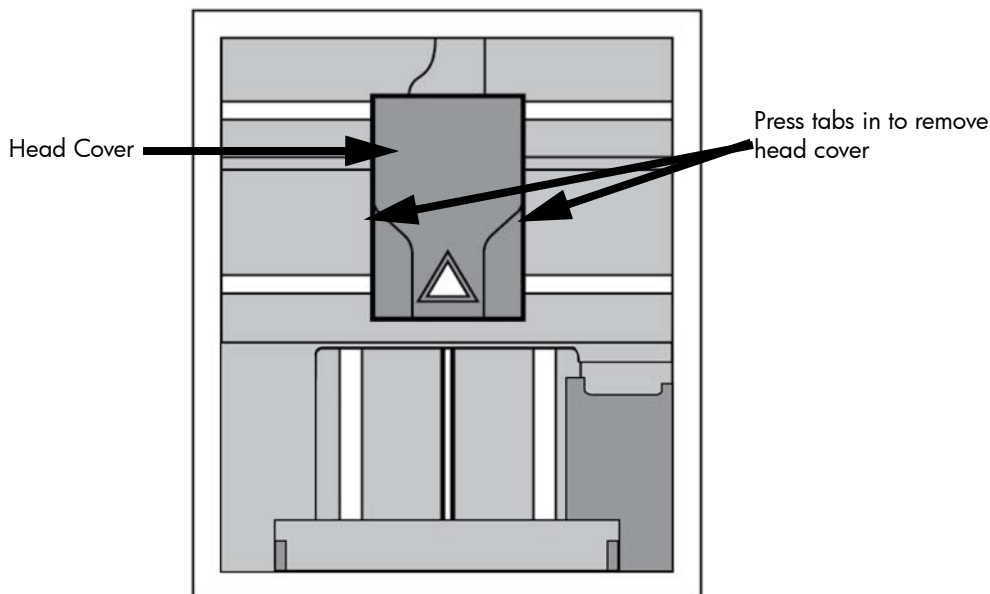
Occasionally, material may become jammed in the head. The system will notify you of a material jam through a message shown on the display panel. If a material jam is detected, follow these steps to clear the jam.

1. From the display panel, press **Continue**.
2. Press **Maintenance**.
3. Press **Machine**.
4. Press **Head**.
5. Once in head maintenance mode, remove the head cover by pressing the tabs in and pulling away from the head. See [Figure 45](#).



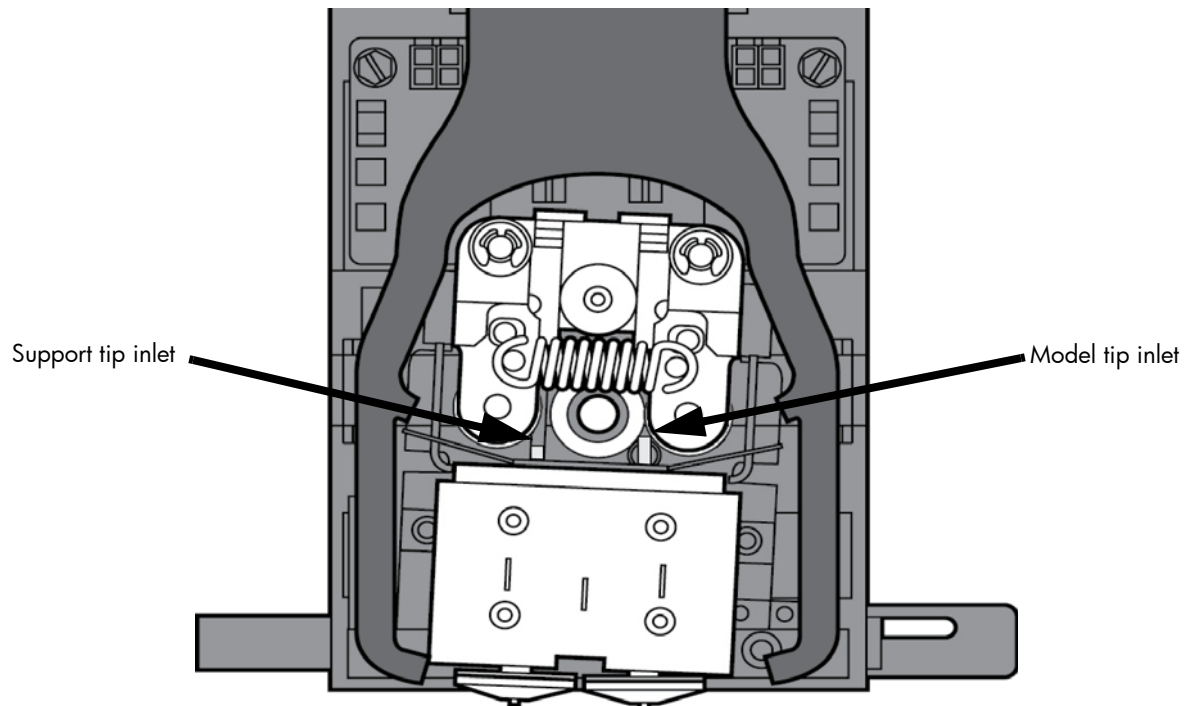
**Gloves:** The head area is hot. Use leather gloves when working in this area of system.

**Figure 45: Remove the head cover**



6. Inspect tip inlets for material build up see [Figure 46](#). If there is excess material build up see ["Recovering from loss of extrusion" on page 56](#). If there is no excess material build up close the chamber door and continue.

**Figure 46: Tip inlet locations**



7. Press **Select Drive** and choose the drive that may have the clogged tip.
8. Press **Forward**, the drive wheel will turn the selected drive forward.
9. Press **Blower Off**, this will turn the head cooling fan off for 10 seconds, allowing the tip to heat up beyond operating temperature. If material starts to extrude the tip is no longer clogged. If material does not extrude see [“Recovering from loss of extrusion” on page 56](#). If material extrudes, you can continue building your part.
10. Reinstall the head cover.



**Note:** If the head cover is not replaced the system may not function properly.

---

11. Press **Done**.
12. Display will ask **Which Materials Loaded?** Press **Both**.
13. Press **Done** until back to **Pause** screen.
14. Press **Resume** to continue building the part.

## Recovering from loss of extrusion



**Note:** It is recommended that you read and understand this entire procedure before performing any of the work.

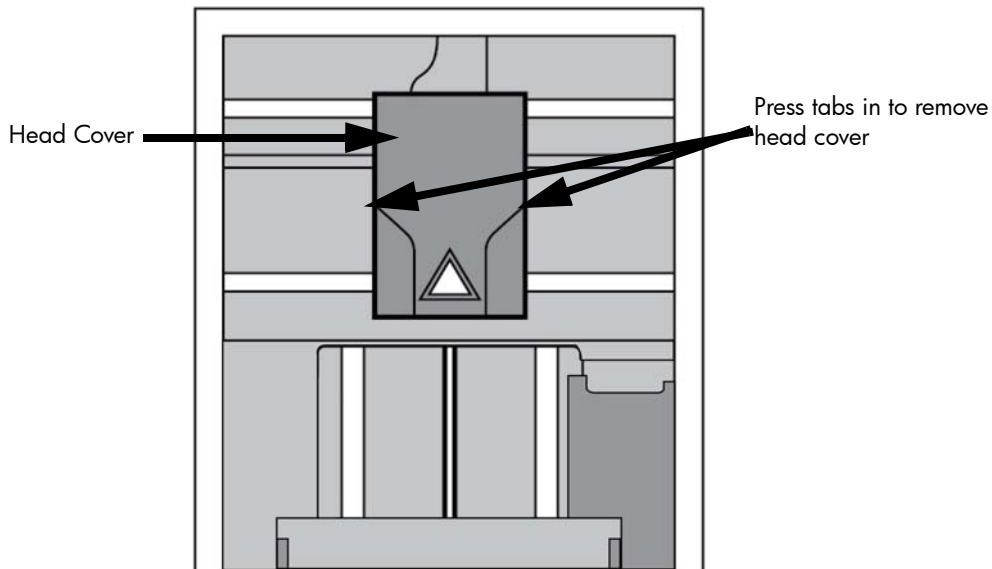
1. Enter **Head Maintenance** mode.
  - a. From **Idle**, press **Maintenance**.
  - b. Press **Machine**.
  - c. Press **Head**. The head will heat up to operating temperature which will take approximately 3 minutes.



**Gloves:** The head area is hot. Use leather gloves when working in this area of printer.

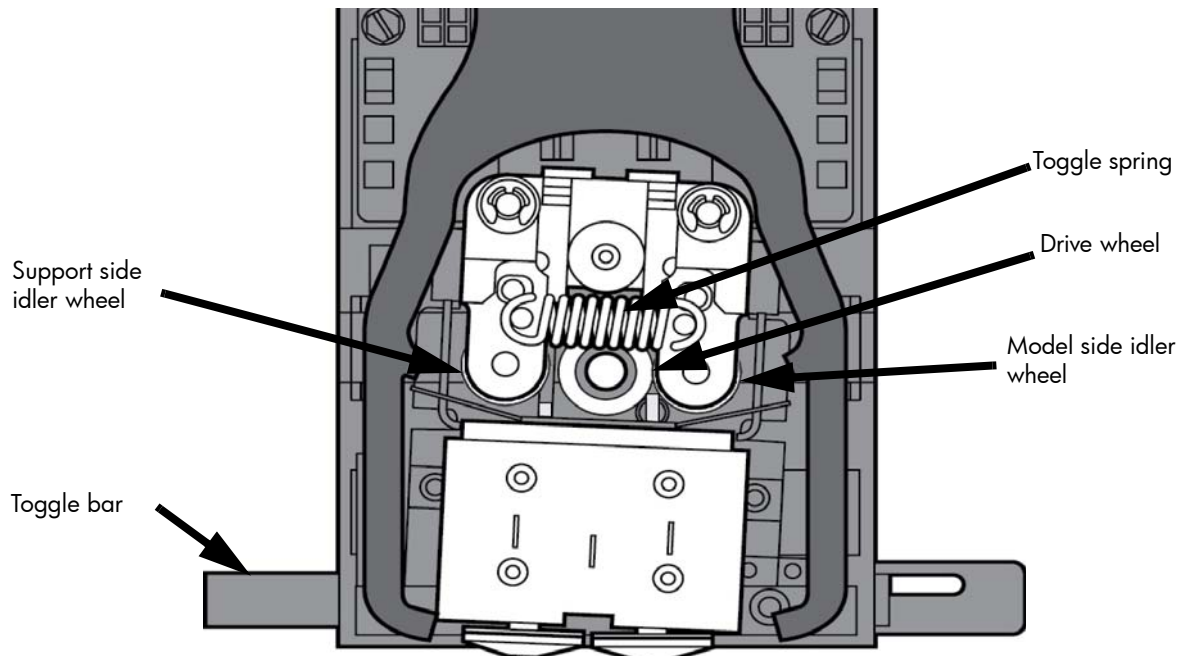
2. Remove the head cover by pressing the tabs in and pulling away from the head. See [Figure 47](#).

**Figure 47: Remove the head cover**

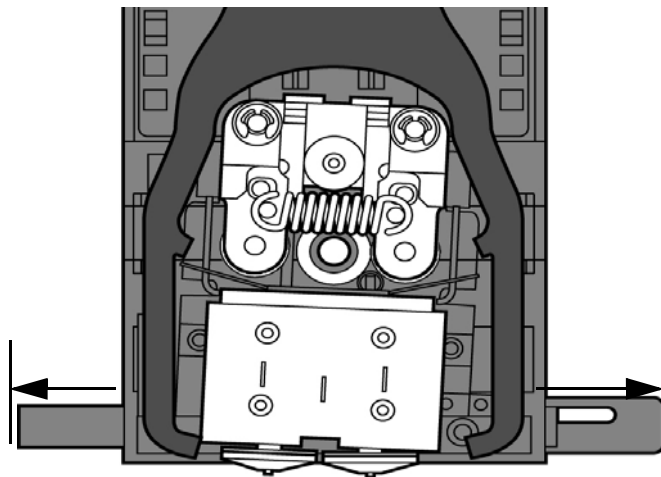


3. Place the toggle bar in neutral position (bar will extend equally from both sides of head). This can be done manually - push on the extended bar end. See [Figure 48](#).

**Figure 48: Head Components**



**Figure 49: Toggle bar in neutral position**



4. Remove any excess material found around the head area.



**Note:** Material fed to the tip can sometimes jam causing a build-up of material under the head cover.

- a. Clean out as much of the material as possible using needle nose pliers, a probe, or equivalent tool.



**CAUTION:** The end of the tip where the material enters is called the extrusion tube. Extrusion tubes are fragile. Use care when working in this area so as to avoid damage to the tubes.

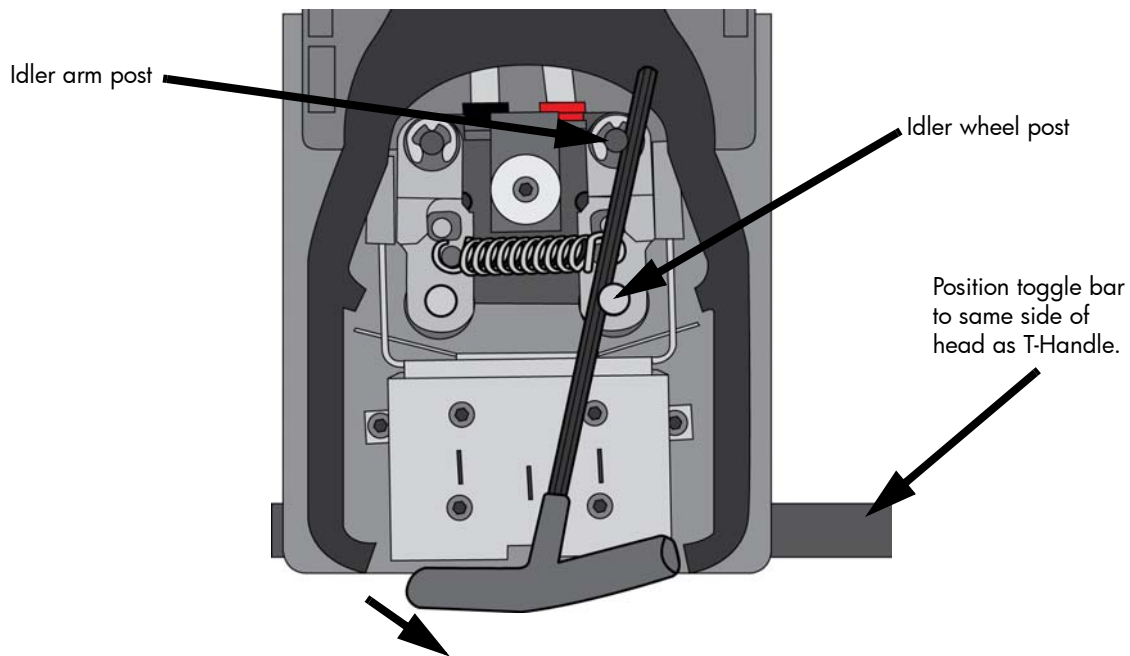
- b. For easier access to areas that may need to be cleaned, move the material idler wheels out of the way (there is one idler wheel for support material and one for model material, see [Figure 48](#).)



**Note:** Move only one idler wheel assembly at a time. Finish cleaning around the moved wheel and restore it to its normal position before moving the other idler wheel. Having both wheels out of position simultaneously could stretch the spring.

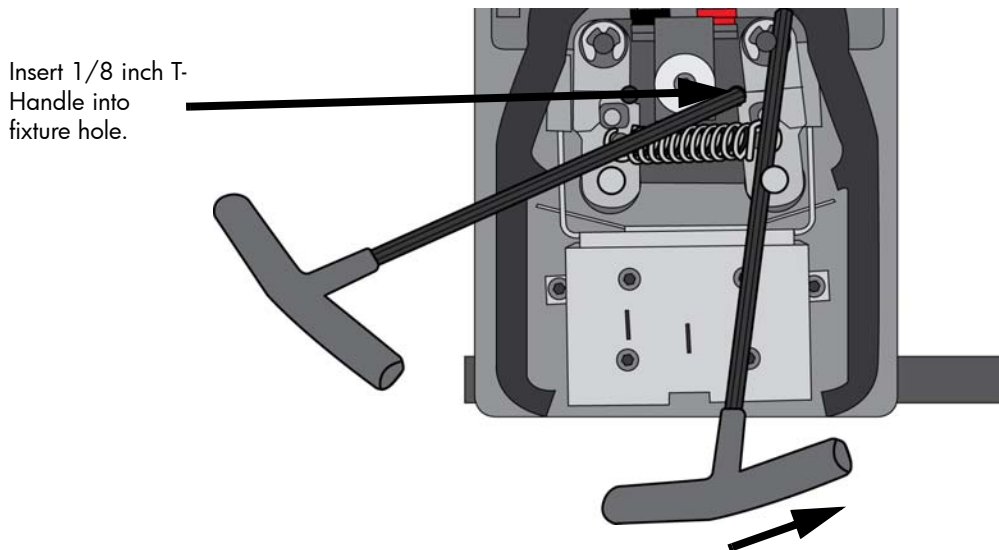
- i. Place a  $\frac{7}{64}$ " T-Handle Allen wrench between the idler arm post and the idler wheel post as illustrated in [Figure 50](#). (model side shown).
- ii. Position toggle bar to the same side of the head as the T-Handle allen wrench. See [Figure 50](#). (model side shown).

**Figure 50: Create access space for cleaning - model side shown**



- iii. Move idler wheel assembly by pushing with  $\frac{7}{64}$ " T-Handle Allen wrench against spring tension. Insert a  $\frac{1}{8}$ " T-handed Allen wrench (from startup kit) into the fixture hole. See [Figure 51](#).

**Figure 51: Holding access space open - model side shown**



- iv. Ease pressure on the  $\frac{7}{64}$ " T-Handle Allen wrench to carefully return the leveraged idler wheel back toward its original position - until the idler assembly is resting against the  $\frac{1}{8}$ " T-Handle Allen wrench.
- v. Remove the  $\frac{7}{64}$ " T-Handle Allen wrench.
- c. Cut the material above the idler wheel using a cutters.
- d. Clean the area that is now accessible using a needle nose pliers, a probe or equivalent tool.



**Note:** Make sure that all loose material is removed from the affected area.

- e. Reposition the  $\frac{7}{64}$ " T-Handle Allen wrench between the toggle spring post and the idler wheel post.
- f. Move idler wheel assembly by pushing with  $\frac{7}{64}$ " T-Handle Allen wrench against spring tension and remove the  $\frac{1}{8}$ " T-handled Allen wrench.
- g. Remove the  $\frac{7}{64}$ " T-Handle Allen wrench.
5. Repeat for the opposite side as needed.
6. Replace the head cover.



**Note:** If the head cover is not replaced the printer may not function properly.

7. Press **Done** on the display panel.
8. Display will ask **Which Materials Loaded?** Press **Model** if only model material is loaded, press **Support** if only support material is loaded or press **Both** if both model and support material are still loaded. Press **None** if neither are loaded.
9. Display will ask you to remove the cartridge of the materials that are not loaded. Remove the cartridge and cut the excess material.
10. Press **Done** until back at **Idle**.
11. Reload the material that is not loaded.

---

# 7 Support

## Customer Support

Contact your local reseller for technical support.

When contacting your reseller please provide the following:

- Your name.
- Your telephone number.
- System model.
- System serial number.
- System software build number.
- CatalystEX version number.
- Detailed description of the problem you are experiencing.
- Please try to be near the printer for troubleshooting, if possible.

*For advanced troubleshooting (provide by email):*

- System CFG file.
- STL and/or CMB files.
- Detailed photographs showing the issue.



---

## 8 Recycling

Visit <http://www.stratasys.com/recycle> for recycling information on material cartridges.

**Figure 52 Recycling Codes**

System Component	Materials	Recycling Code
Modeling bases	ABS	

---

All packaging materials can be recycled per your local recycling guidelines.

---

---

# 9 Printer Specifications

## Physical specifications

Height	1143 mm (45 in)
Width	737 mm (29 in)
Depth	838 mm (33 in)
Weight	148 kg (326 lbs)

## Facility specifications

Installation location	Stable flat surface capable of holding 159 kg (350 lbs).
Power Requirements	100–240VAC ~ 12 - 7A 50/60Hz 1200W dedicated circuit within 2 m (80 in.) Do not use an extension cord or a power strip, using these can possibly cause intermittent power issues.
Air Circulation	115 mm (4.5 in) minimum space behind printer for air circulation. 153 mm (6 in) minimum space around printer for air circulation.
Network Connection	Ethernet 10/100 Base T within 4m (14 ft).

## Workstation specifications

Operating System	Microsoft Windows Vista or Microsoft Windows 7
Processor	Minimum: 2.4 GHz Faster processors will shorten job processing times
RAM	Minimum: 1GB (2GB for Windows Vista or Windows 7) Recommended: 2GB (3GB for Windows Vista or Windows 7)
Hard Disk	Installation: 90MB
Monitor graphics resolution	Minimum: 1024x768 Recommended: 1280x1024 (wide screen acceptable)
Video Card	Required: OpenGL compliant accelerated graphics card Recommended: Hardware support for OpenGL Recommended 128MB graphics card memory

## Power specifications

Source (nominal)	100–240VAC ~ 15 - 7A 50/60Hz 1200W Do not use an extension cord or a power strip, using these can possibly cause intermittent power issues.
------------------	--

## Environmental specifications

Temperature range	15°C to 30°C (59°F to 86°F)
Relative humidity range	30 to 70 percent, non condensing
Heat emission	1080 Watts = 3686 BTU/hr typical 1380 Watts = 4710 BTU/hr max

# 10 Supplemental Information

## Stratasys Limited Warranty Statement

A copy of the warranty is available upon request from [info@stratasys.com](mailto:info@stratasys.com).

## Declaration of Conformity



### Declaration of Conformity

**Manufacturer:** Stratasys Inc.  
7665 Commerce Way  
Eden Prairie, MN 55344-2080

**EU Representative:** Andy Middleton

**Type of Equipment:** Dimension 3D Printers

**Model Numbers:** 180-00105, Dimension Elite  
180-00200, Dimension SST 1200es  
150-00200, Dimension BST 1200es

We declare under our sole responsibility that the devices mentioned above comply with the following EU Directives:

**Electromagnetic Compatibility (EMC):** 2004/108/EC

**Machine:** 2006/42/EC

**Low Voltage:** 2006/95/EC

**Common Technical Specifications used for demonstration of compliance:** EN55022:1998 EN 6100-3-2: 2003  
EN55024:1998 EN 6100-3-3: 1995  
EN60950-1: 2001

**Date of Validity:** February 1, 2013

**Authorized Address:** Stratasys Inc. 7665 Commerce Way Eden Prairie, MN 5534-20804  
Stratasys GmbH Airport Boulevard B 210, 77836 Rheinmunster Germany

**Name of Authorized Signatory:** Mary Stanley Andy Middleton  
**Position Held in Company:** Product Manager General Manager E, ME, A

**Signatures:**

**Stratasys** GmbH  
Airport Boulevard B210  
77836 Rheinmünster  
Tel.: 07229 77 72 0

## Regulatory and environmental information

### EMC Class A Warning



**WARNING:** This is a Class A product. In a domestic environment this product may cause radio interference in which case the user may be required to take adequate measures.

### FCC Statements (U.S.A.)

The U.S. Federal Communications Commission (in 47 cfr1 5.105) has specified that the following notices be brought to the attention of users of this product.

This device complies with part 15 of the FCC rules. Operation is subject to the following two conditions:(1) this device may not cause harmful interference, and (2) this device must accept any interference received, including interference that may cause undesired operation.

**Shielded cables:** use of shielded data cables is required to comply with the Class A limits of Part 15 of the FCC Rules.

Caution: Pursuant to Part 15.21 of the FCC Rules, any changes or modifications to this equipment not expressly approved by Stratatsys, ltd. may cause harmful interference and void the FCC authorization to operate this equipment.

Note: This equipment has been tested and found to comply with the limits for a Class A digital device, pursuant to Part 15 of the FCC Rules. These limits are designed to provide reasonable protection against harmful interference in a commercial environment. This equipment generates, uses and can radiate radio frequency energy and, if not installed and used in accordance with the instructions, may cause harmful interference to radio communications. Operation of this equipment in a residential area is likely to cause harmful interference, in which case the user will be required to correct the interference at their own expense.

### Canada Electromagnetic compatibility (EMC)

#### Normes de sécurité (Canada)

Le présent appareil numérique n'émet pas de bruits radioélectriques dépassant les limites applicables aux appareils numériques de Classe **A** prescrites dans le règlement sur le brouillage radioélectrique édicté par le Ministère des Communications du Canada.

#### DOC statement (Canada)

This digital apparatus does not exceed the Class **A** limits for radio noise emissions from digital apparatus set out in the Radio Interference Regulations of the Canadian Department of Communications.

### MSDS (Material Safety Data Sheet)

You can obtain current Material Safety Data Sheets for the material used in the printer from your local Reseller.

## Disposal of waste equipment by users in private households in the European Union



This symbol on the product or on its packaging indicates that this product must not be disposed of with your other household waste. Instead, it is your responsibility to dispose of your waste equipment by handing it over to a designated collection point for the recycling of waste electrical and electronic equipment. The separate collection and recycling of your waste equipment at the time of disposal will help to conserve natural resources and ensure that it is recycled in a manner that protects human health and the environment. For more information about where you can drop off your waste equipment for recycling, please contact your local city office, your household waste disposal service or the shop where you purchased the product.

---

# 11 Appendix

## Uninterruptible Power Supply (UPS) Use and Installation

The intent of the Uninterruptible Power Supply (UPS) shutdown feature on Dimension and uPrint 3D printers is to prevent required maintenance and/or system damage by safely shutting the system down in the event of an uncontrolled loss of power. Whether an in-process build of a part will complete successfully is dependent on the battery life of the selected UPS and the duration of the power outage.

The user should select a UPS with the following specifications:

- Runtime minimum of 15 minutes at 1000W or 2000VA output (run times >15 minutes may be appropriate based on the typical duration of power outages at the site)
- Runtime minimum 8 minutes after low battery warning tripped.
- Peak output (minimum) of 1500W
- Dry contact (voltage free) interface for “On battery” and “Low battery” conditions
- Dry contact interface capable of carrying at least 100mA at 12VDC.

### General Information

Refer to the UPS and I/O Module (if used) Installation and Operation Guides for instructions on installing the I/O module (if used) into the UPS unit as well as for connecting AC power to the UPS and 3D printer. While connecting the 3D printer power to the UPS will provide some protection against power outages, the 3D printer will shut down safely when “on battery” and “low battery” conditions are detected. Follow the Electrical Interface Connection information below.

1. Configure Normally Open dry contact relay I/Os of UPS as shown in [Figure 53](#) (Wired-And configuration)
2. Build an appropriate length of UPS to 3D printer cable. See [Figure 54](#) for pin out.
3. Connect the cable from the UPS unit’s connector to the UPS (9-pin DSub) connector on the rear of the 3D printer.



**Note:** Make certain to install the jackscrews that hold the cable connectors to their respective mates (do not over-tighten)

---

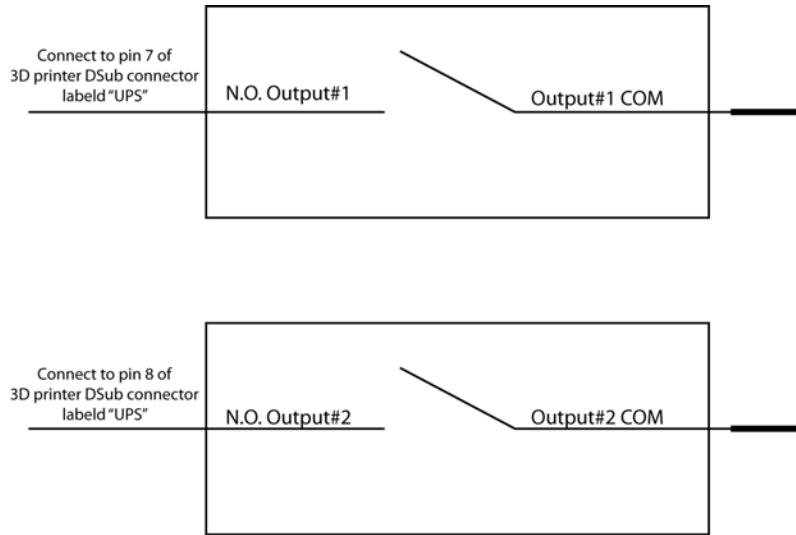
4. Follow the instructions in the UPS Installation and Operation Guide to set the “Low Battery Warning Level” to 8 minutes.



**Note:** The default low battery warning level value may not provide adequate time to ensure the 3D printer can shut down safely.

---

**Figure 53: Wired-And configuration**



**Parts List – Cable, UPS to 3D Printer**

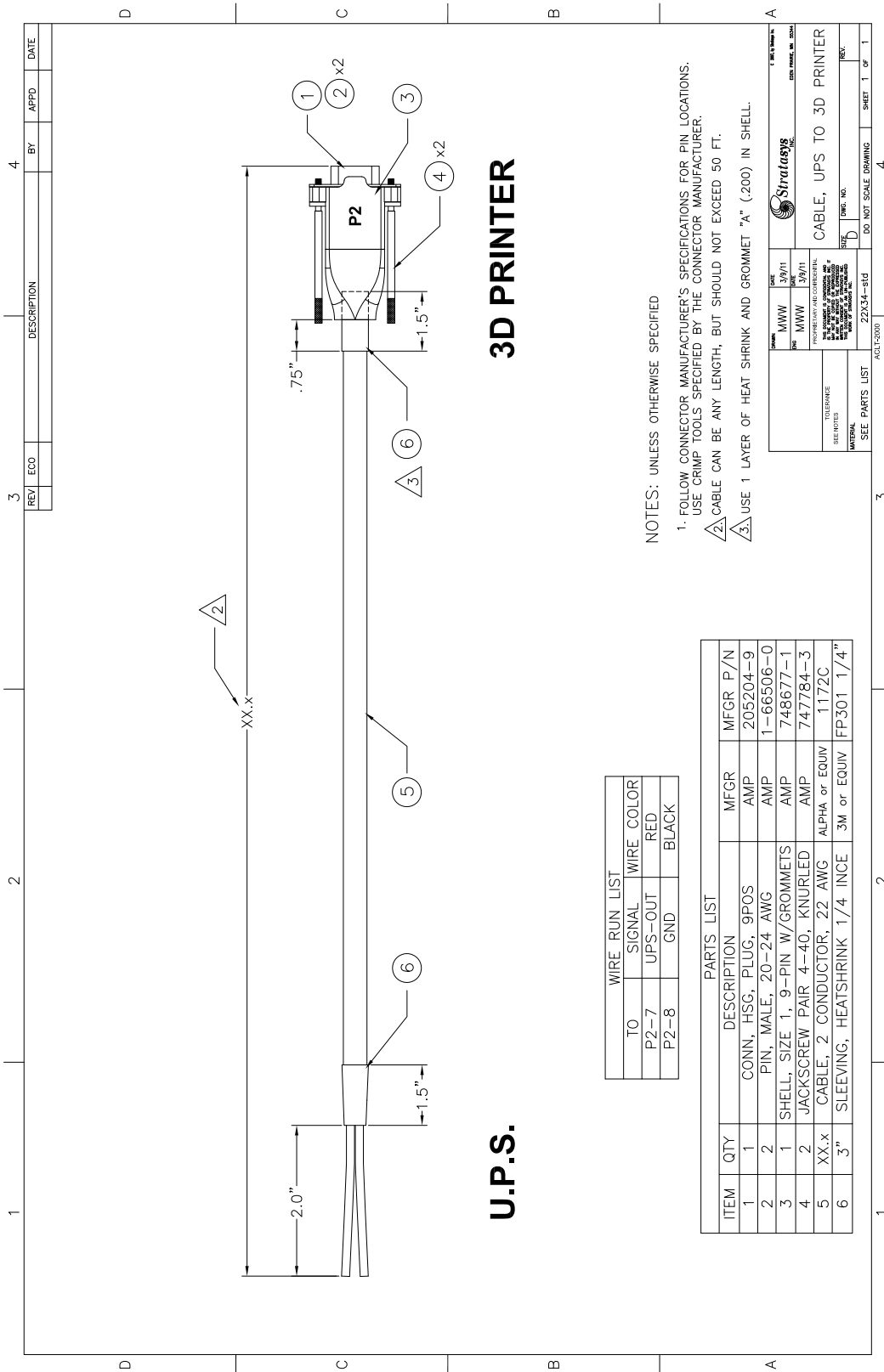
Item	Qty	Nomenclature / Description	Material Specification
1	1	Conn, Hsg, Plug, 9Pos	AMP - 205204-9
2	2*	Pin, Male, 24-20 AWG	AMP - 1-66506-0
3	1	Shell, Size 1, 9-Pin w/Grommets	AMP - 748677-1
4	2	Jackscrew Pair 4-40, Knurled	AMP - 747784-3
5	XX.x	Cable, 2 Conductor, 22 AWG	ALPHA - 1172C or Equivalent
6	3.0 inch	Sleeving, Heatshrink 1/4 Inch	3M - FP301 or Equivalent



**Note:** \* May need additional pins depending on the UPS configuration.



**Figure 54: UPS Cable Diagram**



WIRE RUN LIST			
TO	SIGNAL	WIRE COLOR	
P2-7	UPS-OUT	RED	
P2-8	GND	BLACK	

PARTS LIST			
ITEM	QTY	DESCRIPTION	MFGR P/N
1	1	CONN, HSG, PLUG, 9POS	205204-9
2	2	PIN, MALE, 20-24 AWG	1-66506-0
3	1	SHELL, SIZE 1, 9-PIN W/GROMMETS	748677-1
4	2	JACKSCREW PAIR 4-40, KNURLED	747784-3
5	XX.X	CABLE, 2 CONDUCTOR, 22 AWG	ALPHA or EQUIV 1.172C
6	3"	SLEEVING, HEATSHRINK 1/4 INCE	3M or EQUIV FP301 1/4"

NOTES: UNLESS OTHERWISE SPECIFIED

1. FOLLOW CONNECTOR MANUFACTURER'S SPECIFICATIONS FOR PIN LOCATIONS. USE CRIMP TOOLS SPECIFIED BY THE CONNECTOR MANUFACTURER. CABLE CAN BE ANY LENGTH, BUT SHOULD NOT EXCEED 50 FT.
2. USE 1 LAYER OF HEAT SHRINK AND GROMMET "A" (.200) IN SHELL.

DATE	3/9/11	BY	MWW	CHK	3/9/11
DESIGNED BY	MWW	CHK	MWW	DATE	3/9/11
SEE NOTES FOR DIMENSIONS AND TOLERANCES. ALL DIMENSIONS ARE IN UNLESS OTHERWISE SPECIFIED.					
MATERIAL: SEE PARTS LIST					
SEE PARTS LIST					
22X34-81G					
AULT2000					
DO NOT SCALE DRAWING					
SHEET 1 OF 1					