

Manual de Operaciones de la Fresadora Vertical

Universidad Distrital
Francisco José de Caldas
Facultad Tecnológica

Trust and Reliability

FIRST

**MANUAL OF
OPERATION**

LC- 1½ TM/VS

CONTENTS

1. Foreword	1
2. Safety Rules and Regulations	1
3. LC-1½ VS Variable Speed Milling Machine	2
1) Specifications	2
2) Capacity	2
3) Names of Machine Parts	3
4) Cooling System	6
5) Lubrication	7
6) Instructions in Operations	9
(1) Headstock	9
(2) Machine Body	14
7) Transport, Unpacking and Floor Space	16
8) Precision Alignment	20
9) Trouble-Shootings	24
10) Maintenance	36
11) Feedrate Cutting Speeds	37
12) Cautions	38
4. LC-1½ TM Step Speed Milling Machine	39
1) Specifications	39
2) Capacity	39
3) Names of Machine Parts	40
4) Lubrication	41
5) Instructions in Operations	42
(1) Headstock	42
(2) Machine Body	44
6) Transport, Unpacking and Floor Space	44
7) Precision Alignment	44
8) Trouble-Shootings	45
9) Maintenance	46
10) Cutting Speeds	46
11) Cautions	46
5. Remarks	47

1. Foreword

LONG CHANG LC-1½ VS and LC-1½ TM MILLING MACHINES are designed and manufactured to meet the demands by most of our customers. All parts and materials have been placed under strict quality control to ensure the machine quality superiority and permanent service life.

This manual shall give a detailed account of the structure, mechanism, methods of operation, maintenance, etc. of LC-1½ VS and LC-1½ TM millers. For permanent hi-precision and maximum efficiency of the models, the operators, maintenance and repair personnel are requested to study this manual thoroughly and follow the specific instructions in operations and maintenance exactly.

2. Safety Rules and Regulations

- 1) Wearing of loose clothes by operators is not allowed.
- 2) Operators shall wear the goggles and safety boots.
- 3) Do not allow the body to get too close to the machine while it is in revolution.
- 4) Cautions must be exercised in machine handling in reference to the warnings in this manual.

3. LC-1 $\frac{1}{2}$ VS Variable Speed Milling Machine

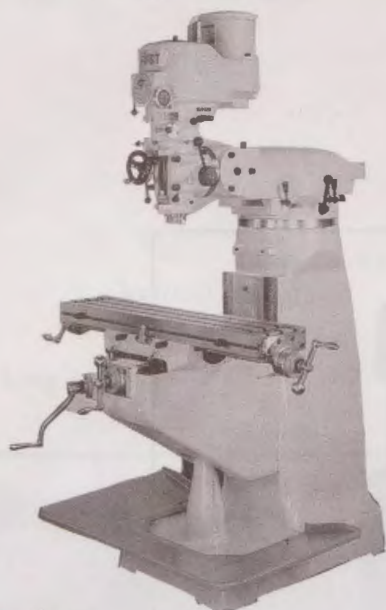

Figure 1

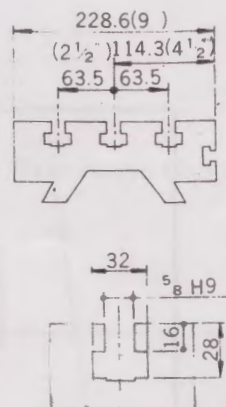

Figure 2

1) Specifications:

STANDARD					
SPECIFICATIONS	INCH	MM	SPECIFICATION	INCH	MM
WORK TABLE			Spindle speed	50HZ	50 – 3750rpm
			R.P.M.	60HZ	60 – 4500rpm
Working area of table	42 x 9	1067 x 230	Machine net weight	2,22Lb	1,010Kg
Table travel (Hand)	30	762	A	56½	1,435
Saddle travel	12	305	B	42	1,067
Knee travel	16	406	C	0 – 12	0 – 305
HEAD			D	0 – 18½	0 – 469
Motor	2HP. 3HP		E	0 – 12	0 – 305
Spindle taper	R8 or N.S.T #30		F	6¾ – 18¾	171 – 476
Quill travel	5	127	G	8¾ – 20¾	222 – 527
Feed rate (PER spindle revolution)	0.0015, 0.003, 0.006	0.04, 0.08, 0.15	OPTIONAL		
Working area of table	50 x 9	1270 x 230	Table travel (Hand)	37¾	960

2) Capacity:

The model features the multi-performances as follows:

- (1) Drilling: Front and oblique drillings.
- (2) Milling: Front, oblique, end, side millings, etc.
- (3) Molding: Irregular curved and drast angle processing.
- (4) Polishing: Surface polish on surfaces of metallic parts.
- (5) Boring: Front and oblique borings by the boring tools installed.

3) Names of Machine Parts:

(1) Headstock:

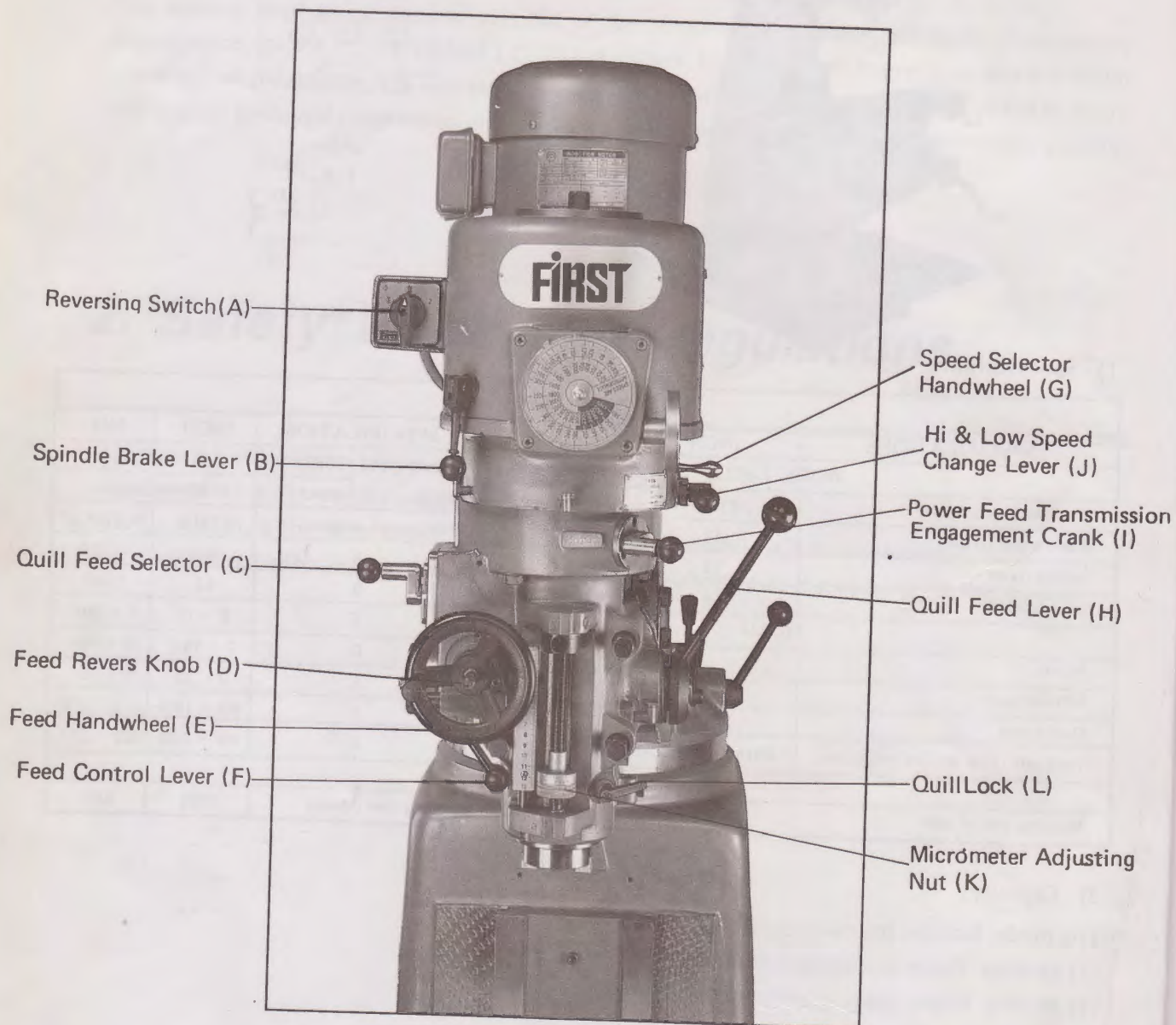

Figure 3

(2) Machine Body:

1) Column, Turret and Ram:

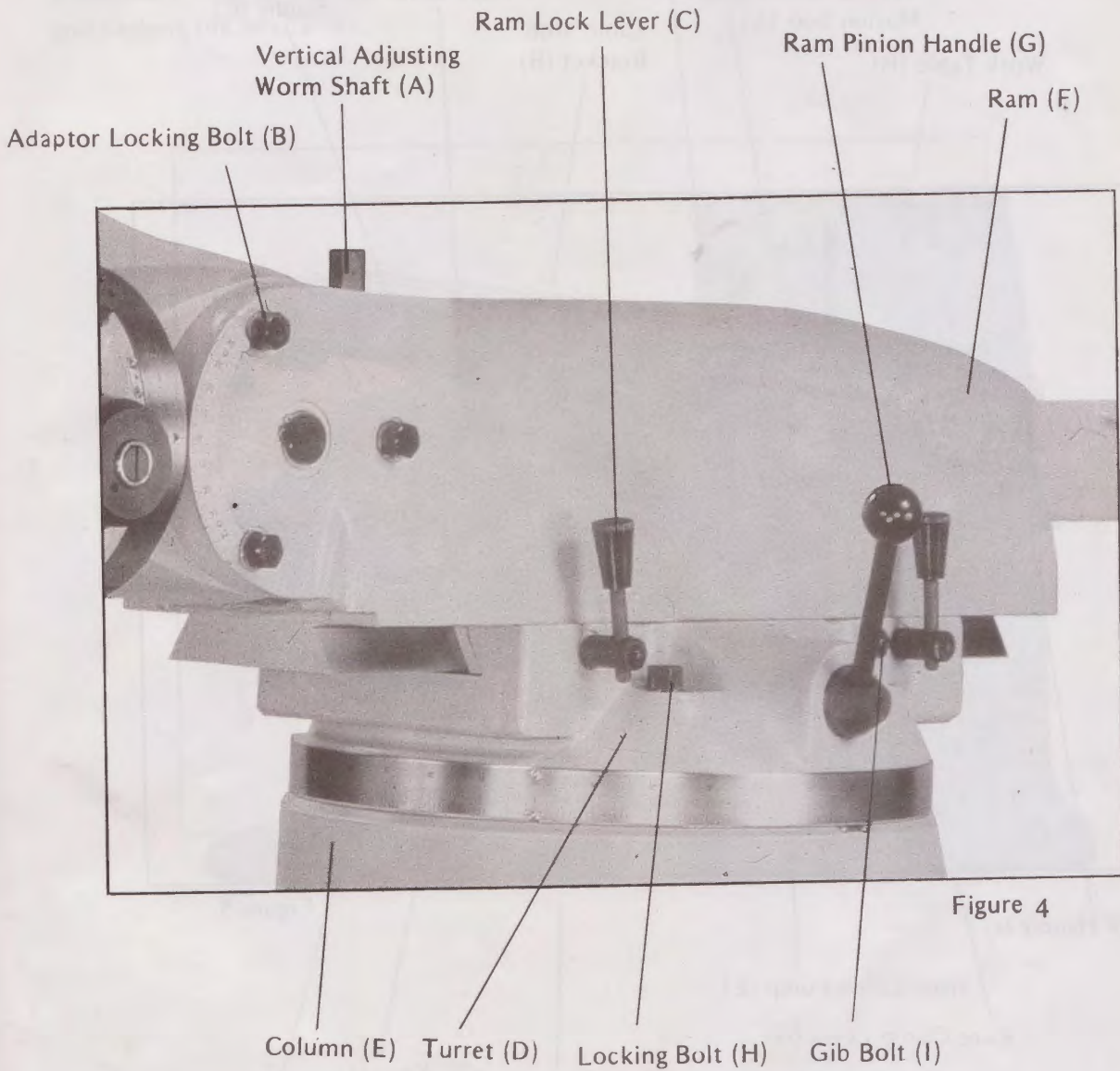
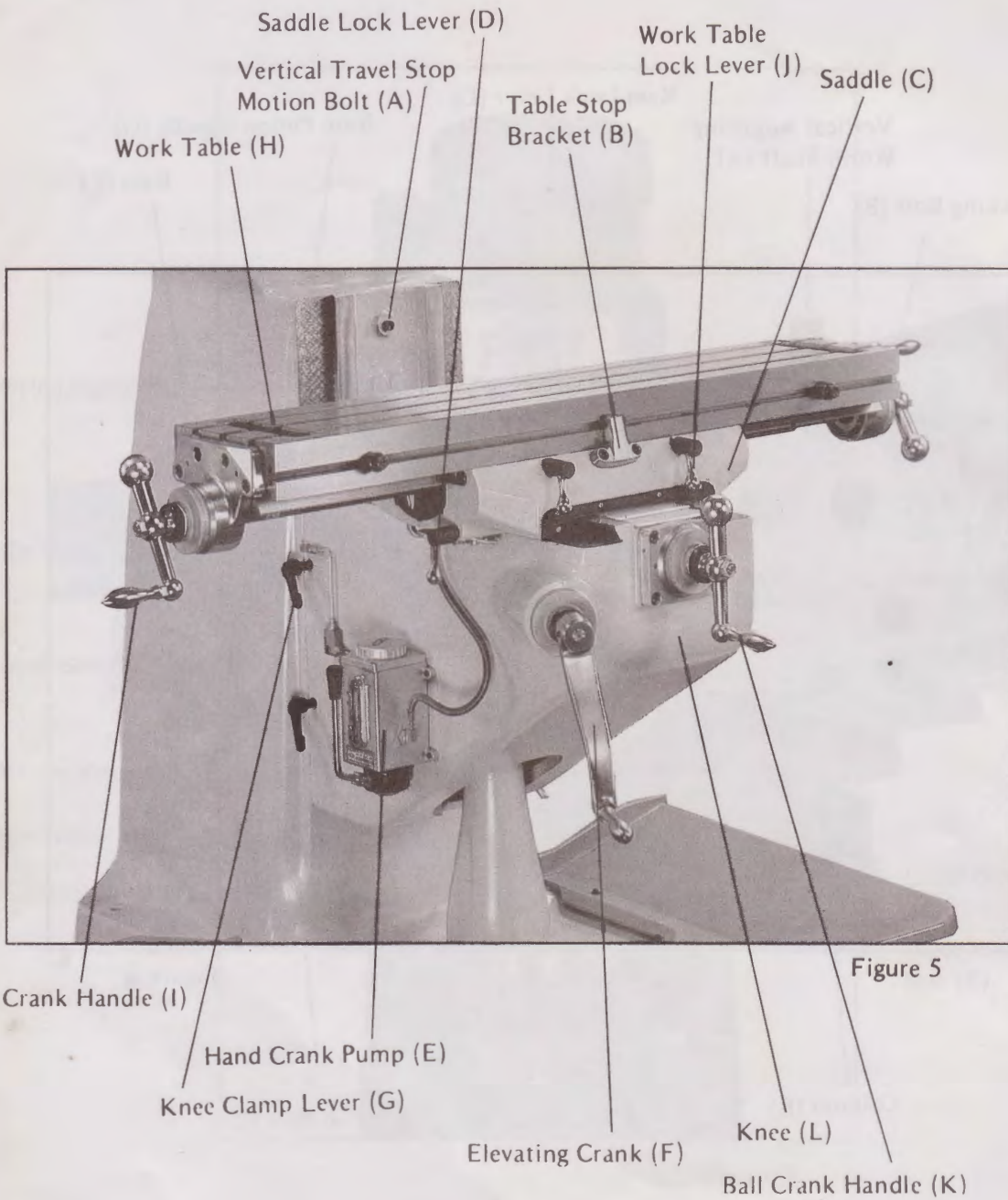

Figure 4

(ii) Work Table, Saddle and Knee:



4) Cooling System:

The variable speed vertical headstock of 1½ VS adopts the unique cooling system of downward double-fan. It is characterized by the installation of the downward cooling double-fan on the oblique surface outside the cover between the front and rear speed change wheels. Since it is not stopped by the speed change belt, the created revolving abrasion heat between the speed change belt and belt wheel may be directed drawn off and exhaust it outside. Therefore, it can effectively prevent the raise of temperature to assure the preciseness of the stepless speed change headstock and prolong the service life.

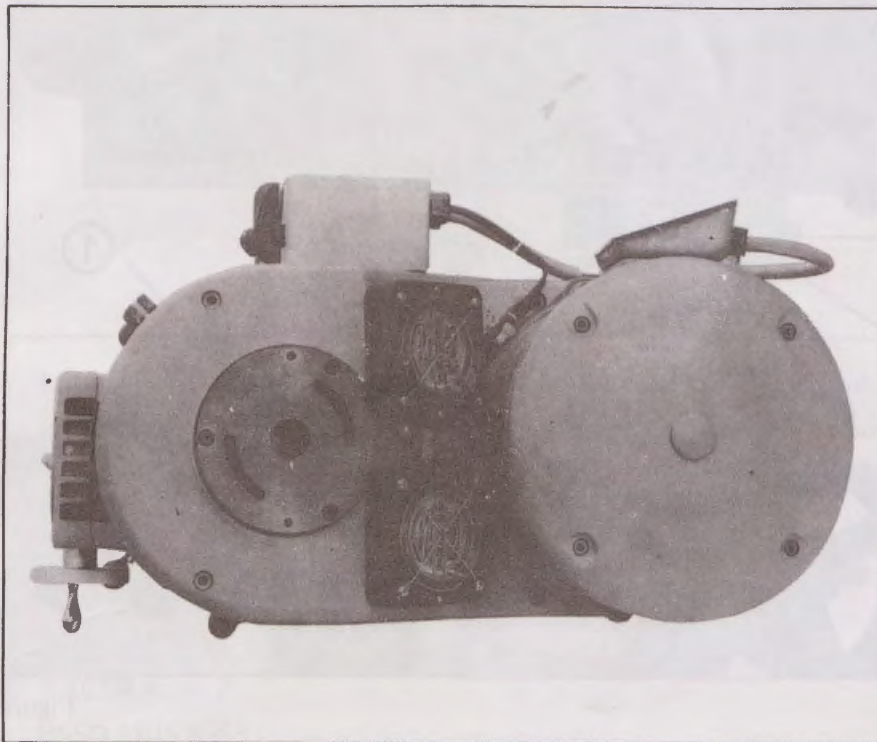

Figure 6

Item	Part Name	Material	Quantity	Unit
1	YACHTER MOTOR	Cast Iron	1	PC
2	COOL FAN	Cast Iron	2	PC
3	COOL FAN MOTOR	Cast Iron	2	PC
4	COOL FAN MOTOR	Cast Iron	2	PC

5) Lubrication

(1) Headstock Lubrication

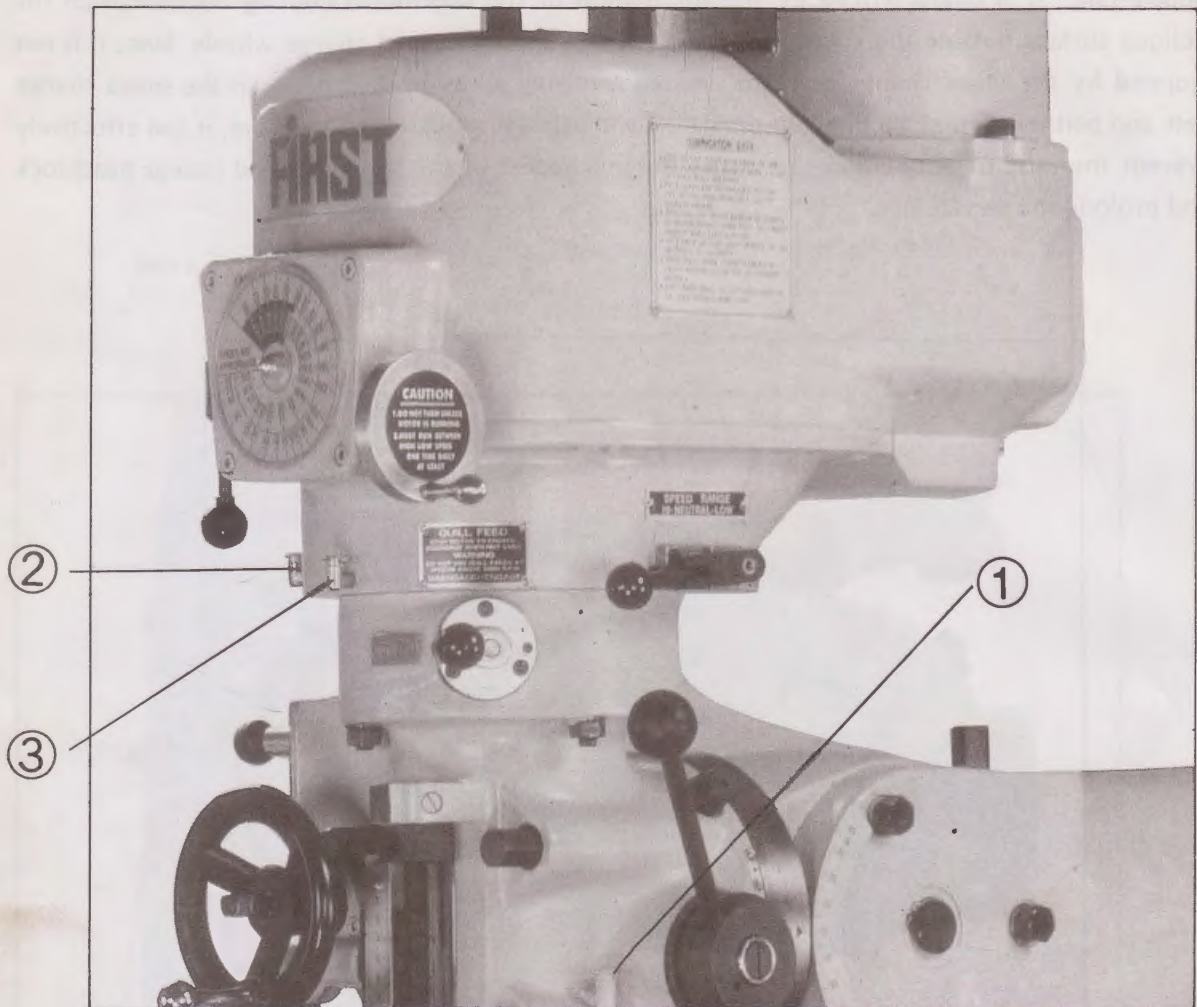

Figure 7

Item	Lubricants	Qty	Time	Position
1	KUO-KUANG R 68 ESSO FEBIS K 53	Full	Twice Daily	Head Stock Matching Quill Holes
2	GULF WAY 52	Full	Twice Weekly	Bull Gear Bearing Sleeve
3	VACTRA NO. 2 SHELL TONNA 33	Full	Once Daily	Counter Shaft Gear Worm Gear Cradle

(2) Machine Table Lubrication

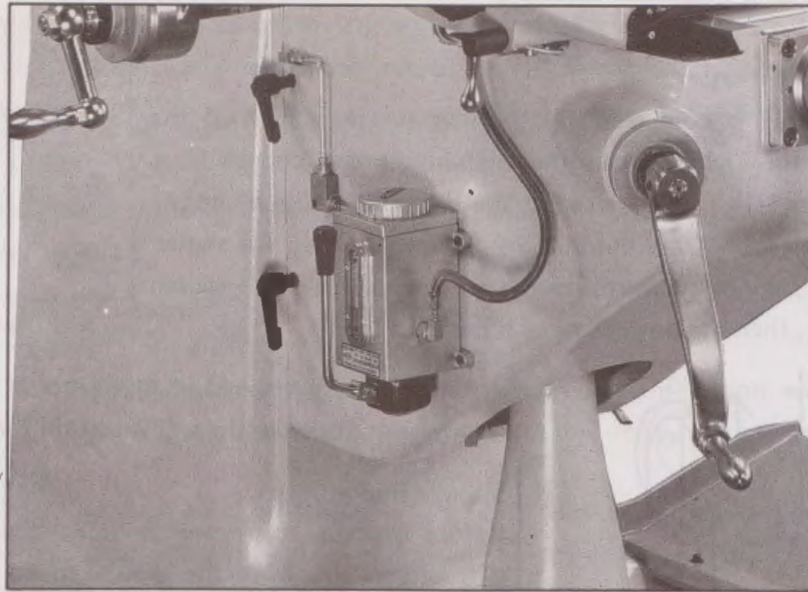

Figure 8

Position:	Lubrication of work table, saddle, knee, sliding surface and leadscrews may be effectuated by means of the hand crank pump on the left side of knee.
Method:	3 to 5 time daily by pulling twice each time.
Lubricant:	KUO KUANG R-68 GULFWAY 52 VACTRA 2 ESSO FBIS K-53 SHELL TONNA 33

6) Operations:

(1) Headstock:

(a) Reversing Switch:

Motor turning is controlled by the reversing switch (Vide the Figure in the right). When the high-low speed change lever (Vide Figure 3(J), P. 3) is placed at the high gear position and the switch is on FOR, the motor turns clockwise. When the switch is on REV, the motor turns counterclockwise. When the switch is on off, then the power source is cut off.

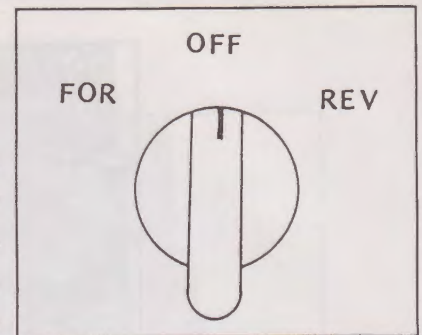

Figure 9

Note: When the high speed change lever is placed at the low gear position, then, it is just on the opposite.

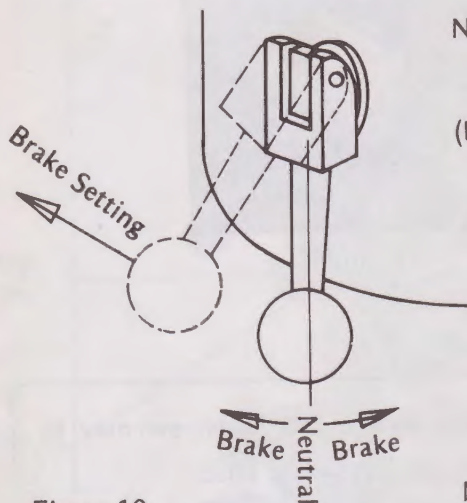

Figure 10

(b) Spindle Brake:

Before braking, the power source must be switched off, and waiting until the spindle speed is lower than 200 RPM before the brake lever (A) (as shown in the figure on the left) is pushed to the left rear or left front to stop the turning and effectuate the bracking. Push the brake lever (A) upward and the quill is braked to a full stop for easy cutter tool change.

Note: Be sure that the brake lever in neutral before starting motor.

(c) Chucking of Tooling Shank and Dismantling:

First the spindle must be raised up to its maximum height. The screw of draw bar is right turn. When the screw is turned clockwise, it is for locking of tooling shank, and vice-versa. To take out the tooling shank, the drawbar must be turned from three to five rounds. Then, use a soft mallet to hit lightly on the drawbar to allow the tooling shank to separate from the spindle. Turn the drawbar, until the tooling shank comes off totally.

Note: According to (b) Spindle Braking, brake the spindle to a stop and the tooling shank may easily come off or chuck on.

Remarks: When the spindle taper is in R8 with key and shank with keyway. It is necessary to turn the tooling shank, in the process of chucking, so that the tooling shank keyway will slide into the key grooves (Vide Figure 36, P. 35).

(d) Manual Feed:

The manual feed lever is installed on the right side of headstock (Vide Figure 3(H), P. 3). The spindle will travel vertically when the lever is turned. There are 12 positions to be chosen. An operator can freely take out the lever and install it again at the position deemed proper and fit.

Note: In manual feed, the feed control handle (F) must be placed at position (F1) as shown in(Figure 11.)

(e) Manual Micromotion Feed:

To effectuate the manual micromotion feed, the powerfeed transmission engagement crank (J) (Figure 11) shall be placed at "OUT" position, and feed reverse knob (D), at the neutral position.

Feed control lever (F) must be pulled from (F1) to (F2). This is to engage the overload clutch. Turn the feed handwheel (E) clockwise for quill downward feed, and vice-versa.

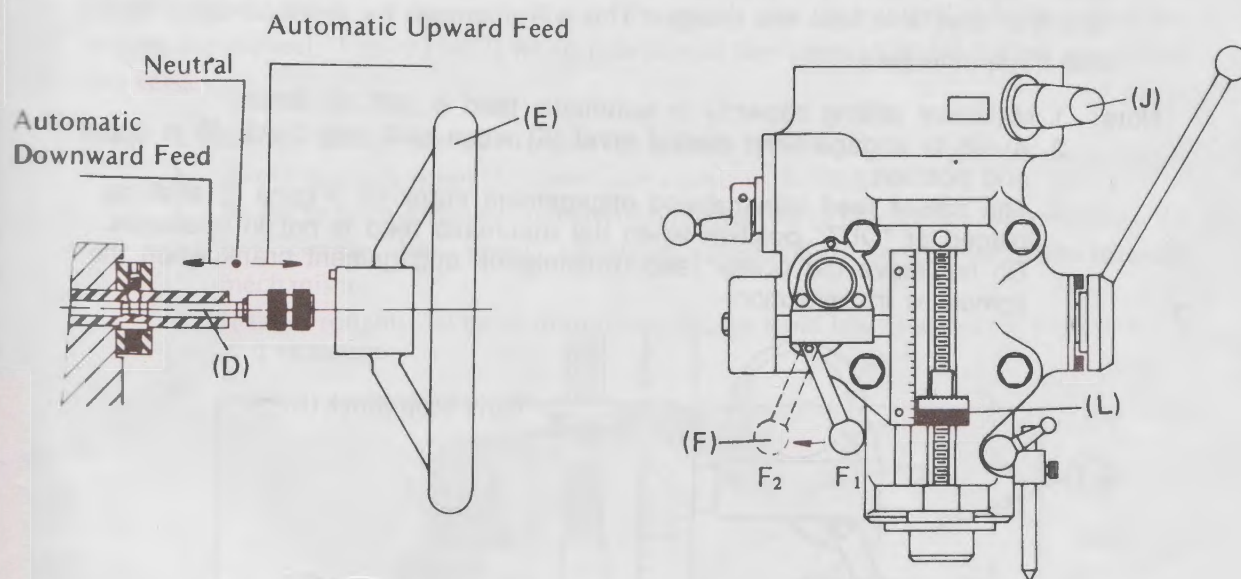

Figure 11

(f) Automatic Feed:

For automatic feeding, please take the following steps (Vide Figure 3, P. 3):

- a'. Loosen the quill lock (L).
- b'. Turn the power feed transmission engagement crank (I) from "OUT" to "IN" position. Make certain to engage the worm gear cradle with the spindle gear hub so that the driving will be directed from the spindle worm and worm gear before it is passed to the speed change gears.
- c'. Feed speed is in three stages. H, L and M. Selection may be made by quill feed selector (C).
- d'. Pull the feed control lever (F) from (F1) to (F2) position (Figure 12) to engage the overload clutch for automatic feed mechanism.
- e'. When the feed reverse knob (D) pressed inward (Figure 11), it is for downward feed, and vice-versa. The middle position is neutral.
- f'. As shown in (Figure 12), the working depth may be set by micrometer adjustment nuts (K) (each graduation is 0.001" or 0.02mm). When the quill stop block (I) contacts the micrometer adjustment nut (K), the feed control lever (F) may simply jump from (F2) back to (F1) position owing to the connecting motion between the feed trip lever and feed trip plunger. This will disengage the overload clutch and stop the spindle feed.

- Note:
1. Maximum drilling capacity in automatic feed is 3/8" or 10mm.
 2. Avoid to engage feed control level (F) when quill stop block (I) in upper end position.
 3. The power feed transmission engagement crank (I) (Figure 3) shall be placed at "OUT" position when the automatic feed is not in operation. Do not move the power feed transmission engagement crank when the spindle is in revolution.

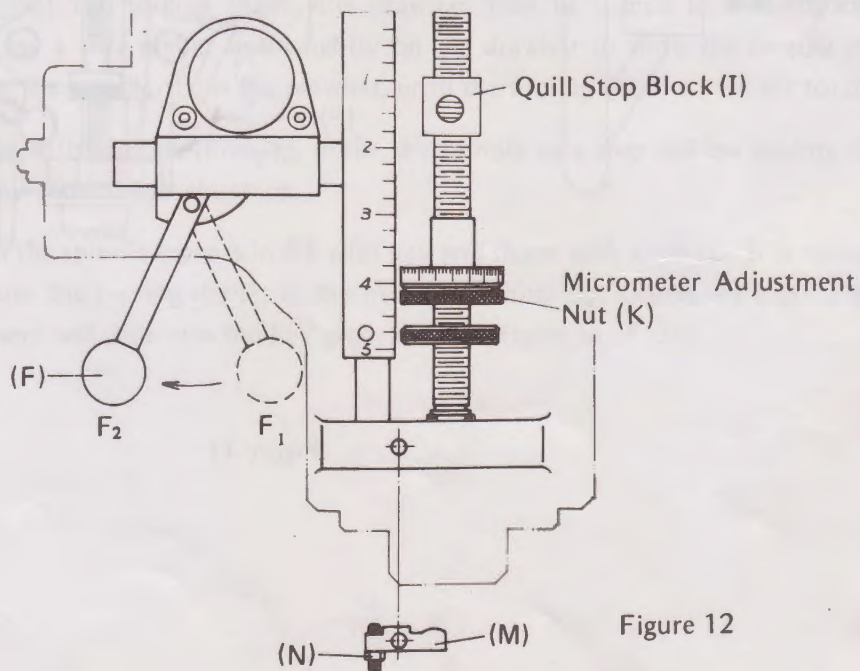

Figure 12

(g) Speed Change of 1½ VS Spindle:

By means of the variation of one set of sliding belt pulley and counter shaft gear (high or low speed), the spindle revolution speed is changed accordingly.

Change of High and Low Speeds:

The speed change may be effectuated by the chosen high and low speed lever (Figure 13(J)). When (J) is engaged in the right front, it is for the high speed and the spindle may rotate as high as 500 to 3,000RPM. When (J) is positioned at the right rear, the spindle may have a speed of 60-580RPM. The neutral lever position is in the right down.

- Note:
- The spindle must be motionless completely during the speed change.
 - To shift the high speed into the low one, the spindle must be slightly turned to make it easier for the backrow gear to engage.
 - To shift the low speed into the high one, use the brake lever so as to put a stop to the spindle clutch. Then turn the spindle slightly so that the clutch may be engaged feasibly. A "click" sound of engagement may be sensed at this moment.
 - The direction of low speed rotation is opposite to that of the high speed. By the reversing switch, the direction may be changed to that of the high speed revolution.

Speed Change Handwheel:

Stepless speed variation between high and low speeds may be controlled by means of the turning handwheel (Figure 13(G)) When it is turned clockwise, it is for higher speed, and vice-versa.

- Note:
- Do not change the speed when the spindle stands still.
 - Avoid to use it when the speed is in excess of 3,000RPM.
 - In the process of speed change from high speed to low speed, and vice-versa, do not change the speed rapidly to safeguard the service life of the internal mechanism.
 - It takes roughly 10 to 15 minutes to change from low speed to the high one, and vice-versa.

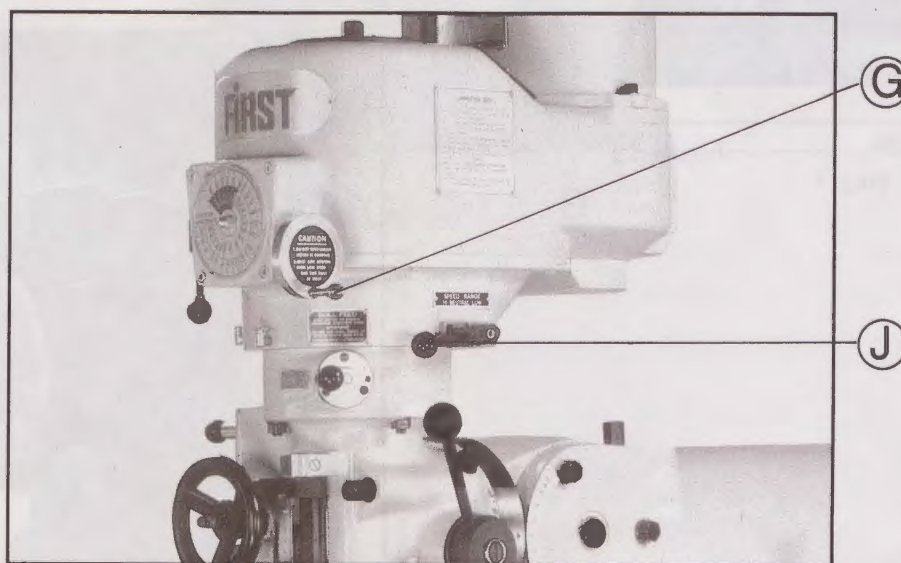

Figure 13

(2) Zero Positioning (as shown in Figure 18) of Dial Ring of Table Feed.

- a. Loosen the nut (D) of dial ring.
- b. Turn the dial ring (E) to zero position.
- c. Lock the nut (D) of dial ring.

(3) Setting of Sliding Surfaces of Work Table, Saddle and Knee:

All non-feed sliding surfaces shall be secured and set to prevent slipping and increase machine body's rigidity. The sliding surface setting levers (as shown in Figure 19) are clockwise for setting and counterclockwise for release.

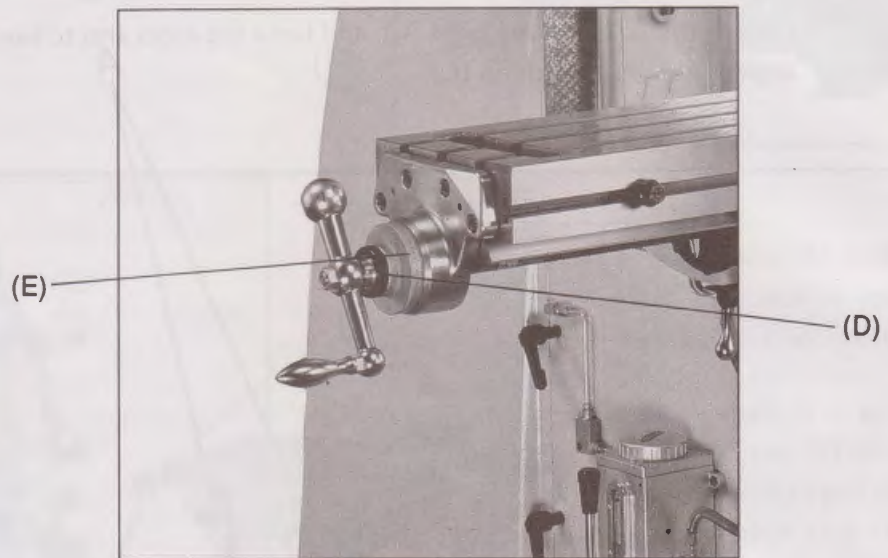

Figure 18

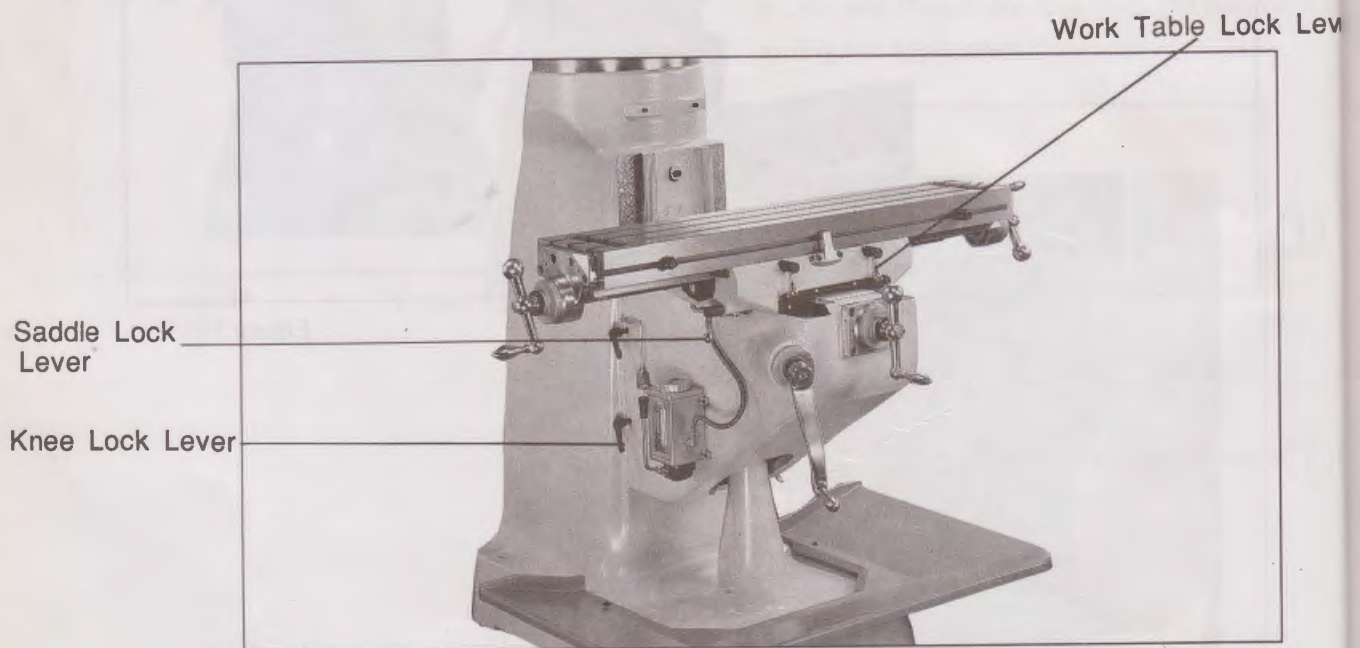

Figure 19

7) Transport, Unpacking and Floor Space:

a) Methods of Transport:

- (1) Prior to unpacking, transport may be made by using a forklift (Figure 20) and a reinforced cable (Figure 21).
- (2) After packing, transport may be made by hoisting with a reinforced cable (Figure 22) and the eye bolt (Figure 23).

Remarks:

- (1) When the machine is being hoisted, keep the personnel afar.
- (2) Hoisting by eye bolt should be used as less as possible.
- (3) To hoist the unpacked case by reinforced cable, the motion shall observe strictly the instruction appeared on the side of the wooden case.
- (4) Keep the work table and saddle in the proper positions so as to keep the machine balance.
- (5) Do not hoist the machine too high. The best position is to keep the machine base approximately 10cm from the ground.
- (6) Do not allow the machine to wobble in hoisting.
- (7) Only an authorized forklift or crane operator is allowed to transport the machine.



Figure 20

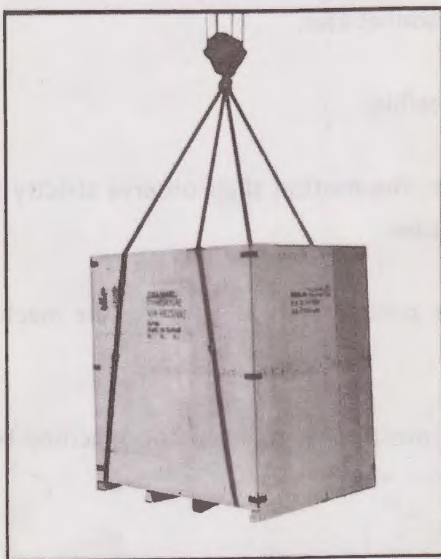

Figure 21

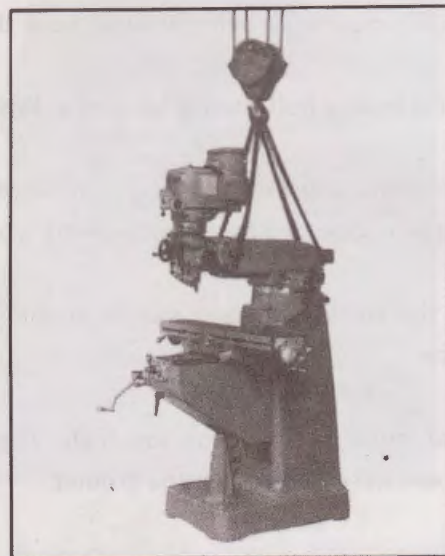

Figure 22

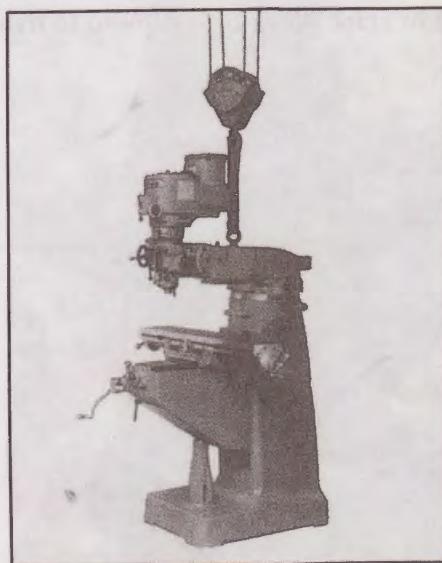

Figure 23

(B) Cautions for Unpacking:

- a. To transport the machine, it is necessary to support the machine with the crated case or pallet to avoid moisture. In case of damage by moistening, please contact our agent or the transporter.
- b. After unpacking, check and see if all tools and accessories are intact, otherwise, please contact our agent.
- c. Restore the headstock to its normal position after unpacking.
- d. After unpacking, do not move the sliding surfaces and work table as long as the rustproof oil on them are not cleaned off and followed with the lubrication.
- e. Before the cleaning starts, the sliding protective pieces must be dismantled, and all sliding surface setting levers, loosened. When the rustproof oil is removed, proper amount of lubricant should be injected onto various sliding surfaces. Then move the sliding surfaces for final cleansing and lubrication.
- f. Do not remove the oil brushes in the process of cleaning.
- g. Do not use gasoline or any other inflammable oil cleaner.

(C) Floor Space:

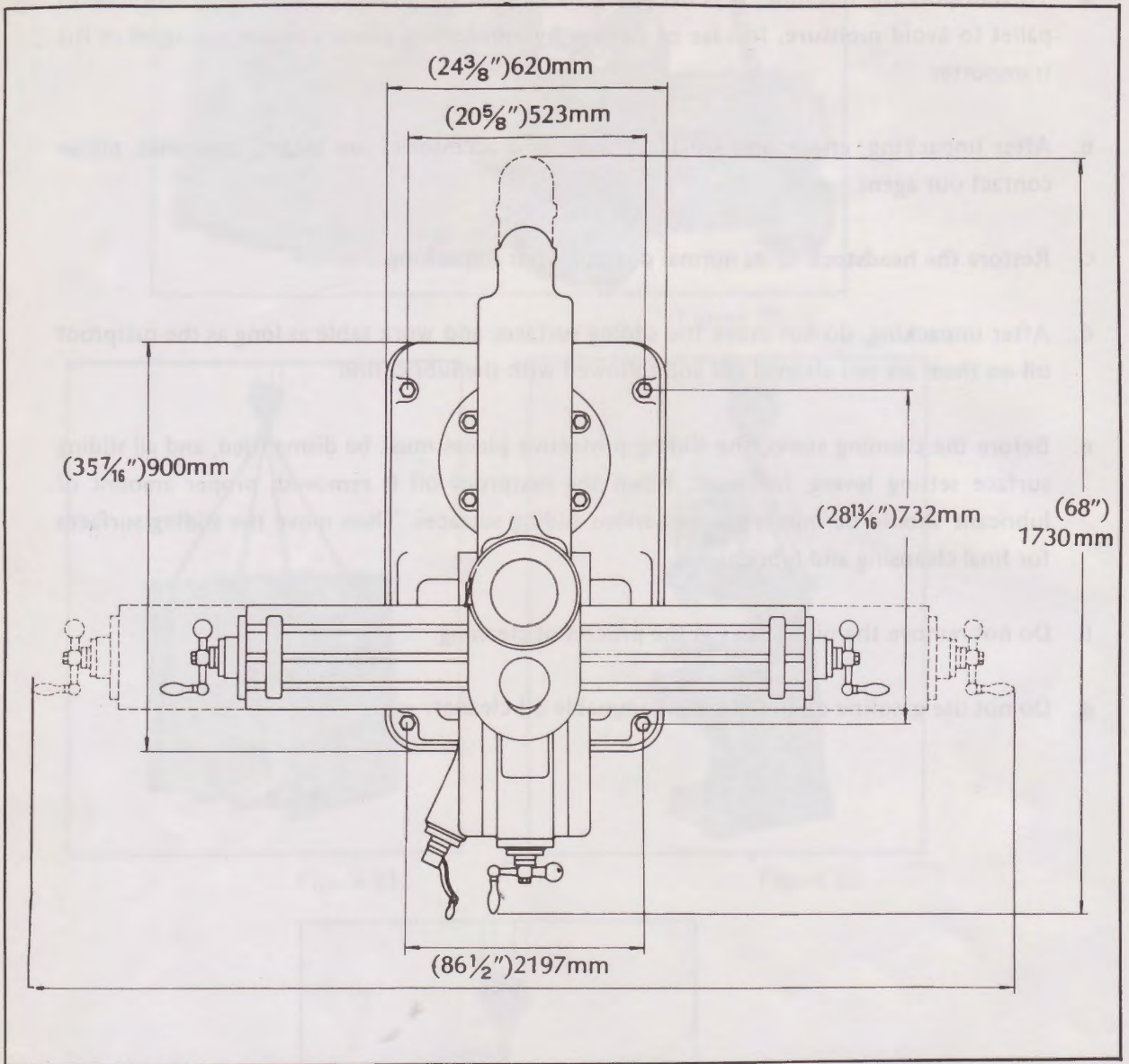

Figure 24

(D) Machine Height: 2070 (81½")

8) Precision Alignment:

Precision of a machine dominates the processing quality. To produce the quality workpiece, precision of each and every components is a top priority.



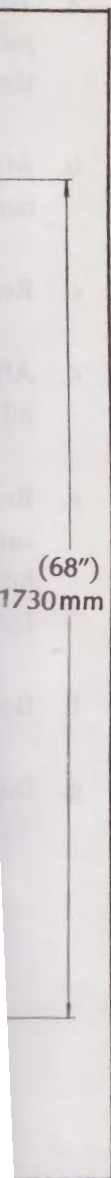

In order to maintain the primary machine precision following a long-term operation, regular precision alignment is indispensable to the upgrading of work quality. Beside, it may extend the machine service life. For details of components to be aligned and precision requirements, please vide the Table of Precision Inspection.

Note: To align the verticality of spindle to the table surface, it is necessary to loosen the three machine head bolts (Vide Figure 14(P), P. 13) and the four machine head nuts (Vide Figure 15(R), P. 13). However, the bolts and nuts can not be loosened totally to prevent the components from a sudden tilting. Lock up (P) and (R) as soon as the alignment is performed.



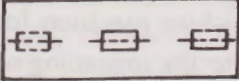

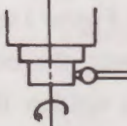
<p>VERTICAL MOVEMENT OF SPINDLE</p>		<p>TO ACTION OF SPINDLE FLANGE</p>
<p>SPINDLE HOLD ROD AT END OF SPINDLE</p>		<p>SPINDLE HOLD ROD AT END OF SPINDLE</p>
<p>LONGITUDINAL MOVEMENT OF TABLE WITH SPINDLE</p>		<p>LONGITUDINAL MOVEMENT OF TABLE WITH SPINDLE</p>
<p>CROSS MOVEMENT OF TABLE WITH SPINDLE</p>		<p>CROSS MOVEMENT OF TABLE WITH SPINDLE</p>

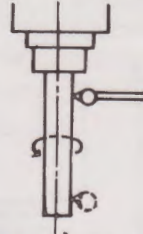
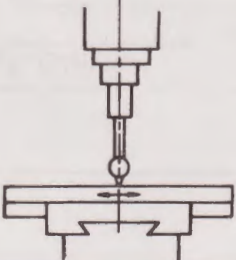
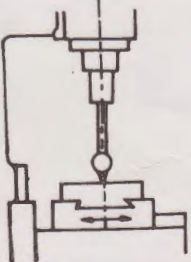
PRECISION TEST REPORT

No.	TEST ITEM	TEST ILLUSTRATION	Allowable Error (mm)	MEASURED mm
1	STRAIGHTNESS OF TABLE TOP LONGITUDINAL DIRECTION		0.06/m	
	CROSS DIRECTION		0.06/m	
2	SPINDLE NOSE RUN OUT		0.01	
3	CAM ACTION OF SPINDLE FLANGE		0.015	
4	SPINDLE HOLD RUN OUT AT END OF SPINDLE NOSE		0.01	
	AT END OF 300mm TEST BAR		0.02	
5	PARALLELISM OF LONGITUDINAL MOVEMENT OF TABLE WITH IT'S TOP		0.03	
6	PARALLELISM OF CROSS MOVEMENT OF TABLE WITH IT'S TOP		0.02	

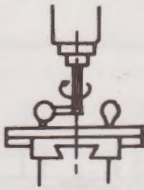
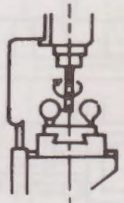
No.	TEST ITEM	TEST ILLUSTRATION	Allowable Error (mm)	MEASURED (mm)
7	PARALLELISM OF LONGITUDINAL MOVEMENT OF TABLE WITH MIDDLE T-SLOT		0.03	
8	SQUARENESS OF CROSS MOVEMENT OF TABLE WITH MIDDLE T-SLOT		0.02	
9	SQUARENESS OF VERTICAL MOVEMENT OF SPINDLE HEAD WITH TABLE TOP LONGITUDINAL DIRECTION		0.025	
	CROSS DIRECTION HIGH AT FRONT OF TABLE		0.025	
10	SQUARENESS OF TABLE TOP WITH VERTICAL MOVEMENT OF KNEE LONGITUDINAL DIRECTION		0.02	
	CROSS DIRECTION HIGH AT FRONT OF TABLE		0.02	

No.	TEST ITEM	TEST ILLUSTRATION	Allowable Error (mm)	MEASURED mm
	SQUARENESS OF TABLE TOP WITH SPINDLE LONGITUDINAL DIRECTION		0.02	
11	CROSS DIRECTION HIGH AT FRONT OF		0.02	
				

9) Trouble Shootings:**(1) Dismantling of 1½ VS Motor (as shown in Figure 25):**

- a. Start the motor and turn the speed change handwheel (A) to the position of 60RPM appeared on the indicator to lower down the stationary motor vari-disc to the lowest position.
- b. Cut off the motor power source and take off wire pressboard and reversing switch.
- c. Remove motor pulley cover (B) under the motor shaft. Then, use the two hexagonal concave bolts (C) that locked the bearing housing, to insert into the two holes of the speed change spring pieces (D). Lock into the motor vari-disc (E) and evenly lock up the two bolts (C). Push down the speed change spring (F) so as to separate it from the retainer ring (G).
- d. Take out the retainer ring (G).
- e. Take off the two hexagonal bolts (H) that locked the motor. The motor may be lifted up. Motor vari-disc (E) and speed change belt are still kept inside the belt housing.
- f. Once the motor is replaced, just reverse the order of dismantling.

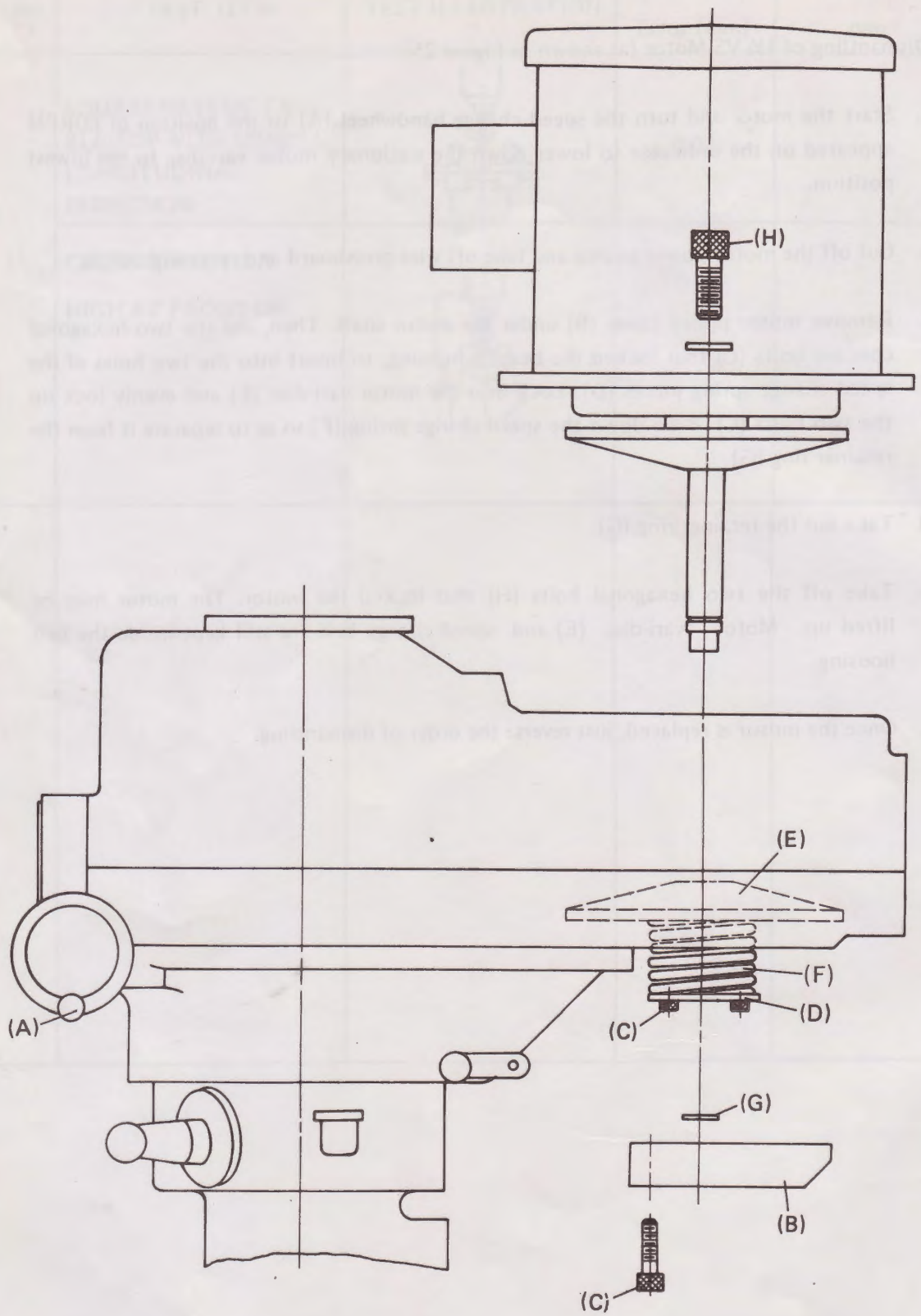

Figure 25

(2) Replacement of Speed Change Belt (as shown in Figure 26):

- a. Refer to Step a to e of motor dismantling on P. 24.
- b. Take off draw bar (I).
- c. Dismantle the three hexagonal concave bolts (J) and use two of them (J) to lift the bearing housing (K).
- d. Remove from atop the two hexagonal concave bolts (L), fixing the speed change plate, and take off the bolt sleeves (M).
- e. Dismantle four hexagonal concave bolts (N) (O) and the two at the bottom (P).
- f. Take off the two hexagonal concave bolts (S) speed change housing (Q) and gear housing (R).
- g. Use a mallet and hit the upper belt housing (T) lightly so that it will break away from the fix pin (U) for dismantling of the upper belt housing.
- h. When the speed change belt is replaced accordingly, restore the machine by reversing the orders.

Note: The replaced speed change belt shall conform to that of our company specifications.

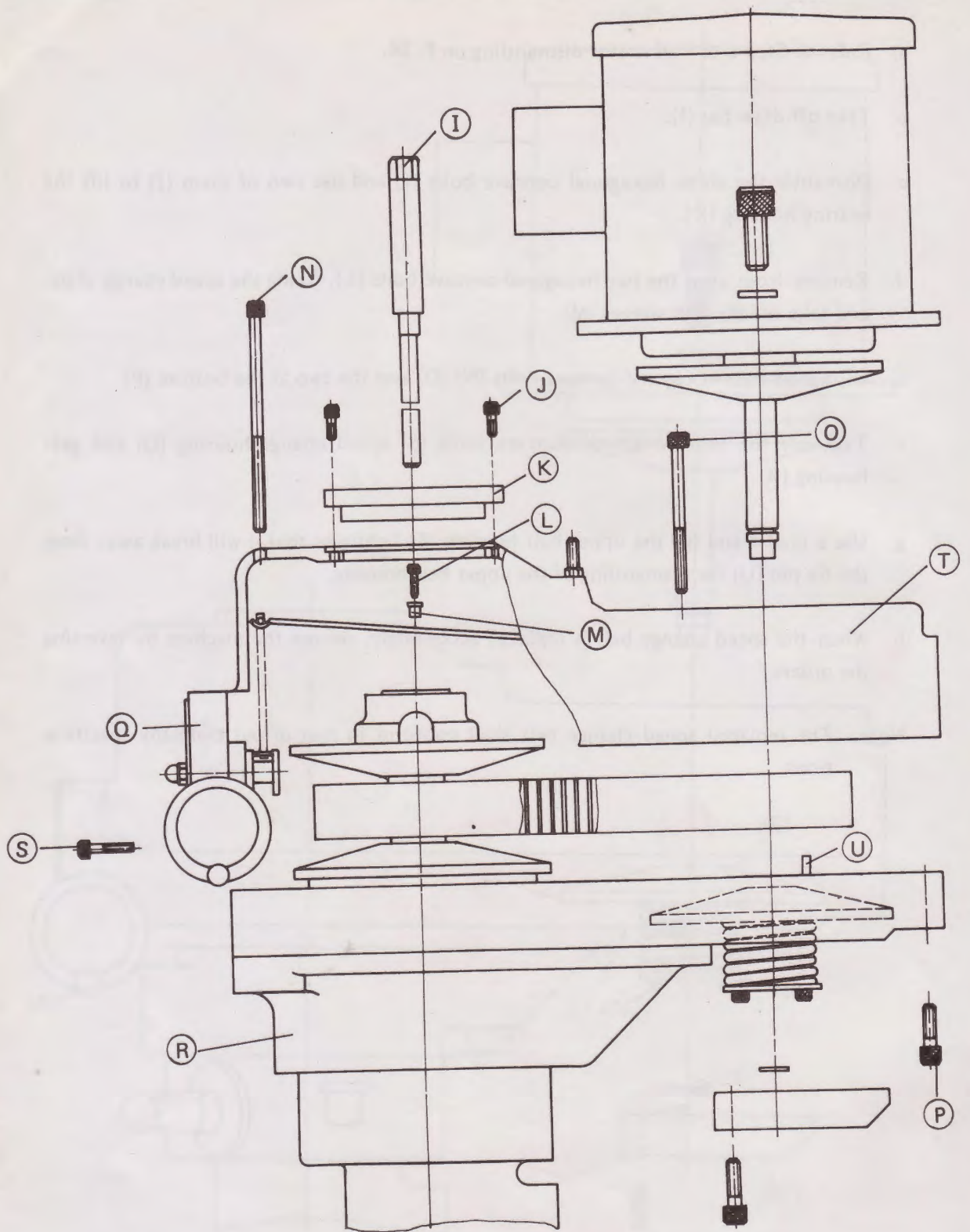

Figure 26

(3) Replacement of Brake Block (Figure 27):

- a. Refer to Step a to e on P. 24 on motor dismatling.
- b. Refer to Step b to g on P. 26 on replacement of speed change belt to dismantle the upper belt housing.
- c. As shown in Figure 28, take off the connected gear housing (R) and the four hexagonal concave bolts (V) bottom belt housing (T1).
- d. Use a soft mallet and hit the bottom belt housing lightly to disengage it with the fix pin (W) to dismantle the bottom belt housing (T1) as shown in Figure 28.
- e. Take off the hexagonal concave bolt (X) of the two setting bearing housing and remove the front vari-disc assembly set (E1). Brake block (Y) can be replaced then.
- f. Reverse the order to restore the machine assembly after the brake block is replaced.

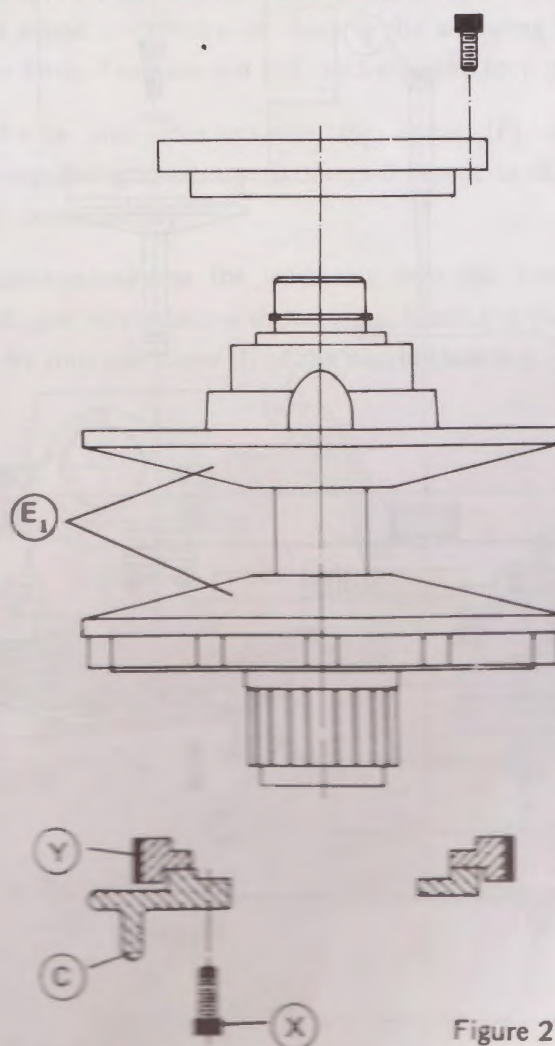

Figure 27

(4) Replacement of Timing Belt:

- a. Refer to Step a to e of motor dismantling on P. 24.
- b. Refer to Step b to g speed change belt replacement on P. 26 to take off the upper belt housing.
- c. Refer to Step c to d on P. 28 replacement of brake block for the dismantling of bottom belt housing and change the timing belt as shown in Figure 28.
- d. Restore the machine structure by reversing the steps once the timing belt is replaced.

Note: Belt to be replaced shall conform to the manufacturer's specs.

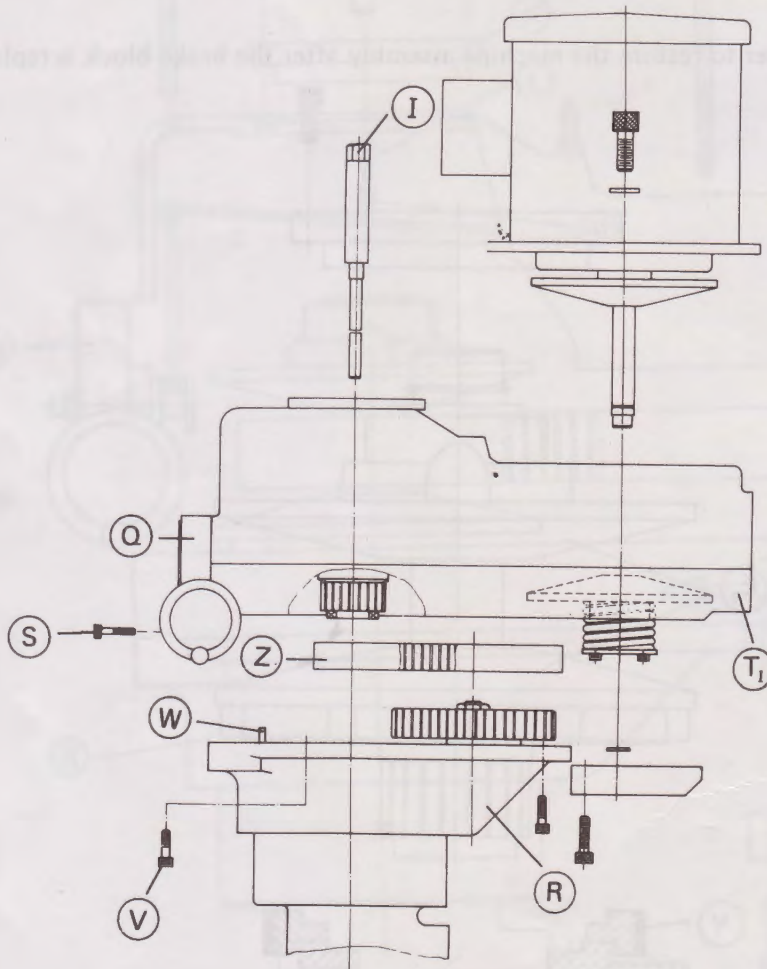

Figure 28

(5) Adjustment of Backlash of Leadscrew:

After a certain period of time, a clearance is developed between the leadscrew and its nut due to frictions. Positioning accuracy will become impossible. Therefore, the nut must be adjusted so as to keep a proper tension between itself and the leadscrew.

A. Adjustment of cross leadscrew (Vide Figure 29):

- a. Turn counterclockwise the crank (F) and move the saddle seat to the foremost position of knee.
- b. Remove the two setting pins (H) of the front bearing bracket (G) and take off the four socket HD cap screw (I).
- c. Support the cross feed bearing bracket (G) and turn clockwise the crank (F) so that the bracket will be separated from the knee with a certain distance between them (as shown in Figure 30, the distance must be longer than the length of the adjusting tool).
- d. Insert the larger end of clearance adjusting tool into the knee and turn the locking nut (J) one round anticlockwise. Reverse the adjusting tool and insert the smaller end into the knee. Turn the nut (K) clockwise and lock it up.
- e. Turn clockwise and anticlockwise the crank (F) and measure a clearance of approximately 3-4 graduations (0.06mm-0.08mm or 0.003"-0.004") on the dial. Lock up (J) consequently.
- f. Turning counterclockwise the leadscrew into the knee until the front bearing bracket seat gets in contact with the knee. Insert the two setting pins (H) and lock up tightly the four cap screw (I) of the bearing bracket.

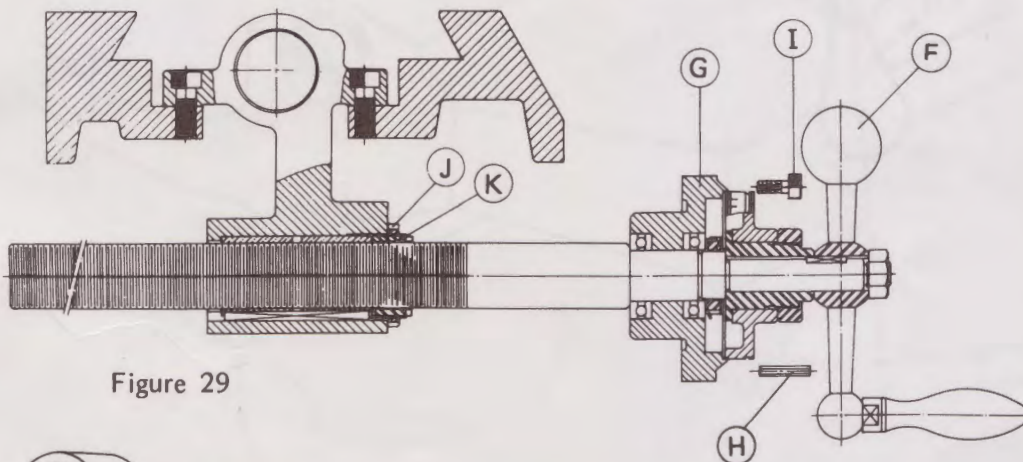

Figure 29

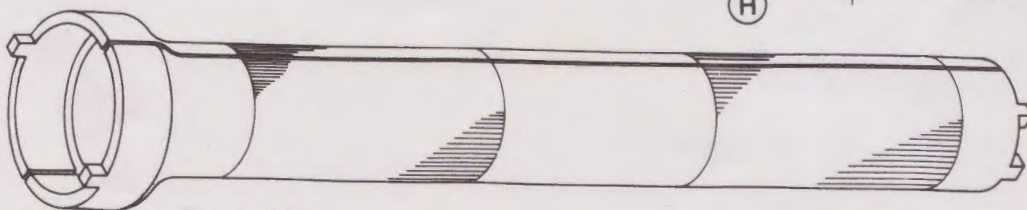

Figure 30

B. Adjustment of Backlash of Longitudinal Leadscrew:

- a. Move the work table to the center of saddle.
- b. Insert the large end of backlash adjustment tool into the left side of saddle. Turn the locking nut (J) counterclockwise one round. Reverse the end of adjustment tool and insert the small end into same position and turn the leadscrew adjusting nut (K) clockwise.
- c. Turn the crank (F) slightly clockwise and counterclockwise and measure a clearance of approximately 3 to 4 graduations on the dial (0.6-0.08mm or 0.003"-0.004"), before the nut is locked up tightly again.

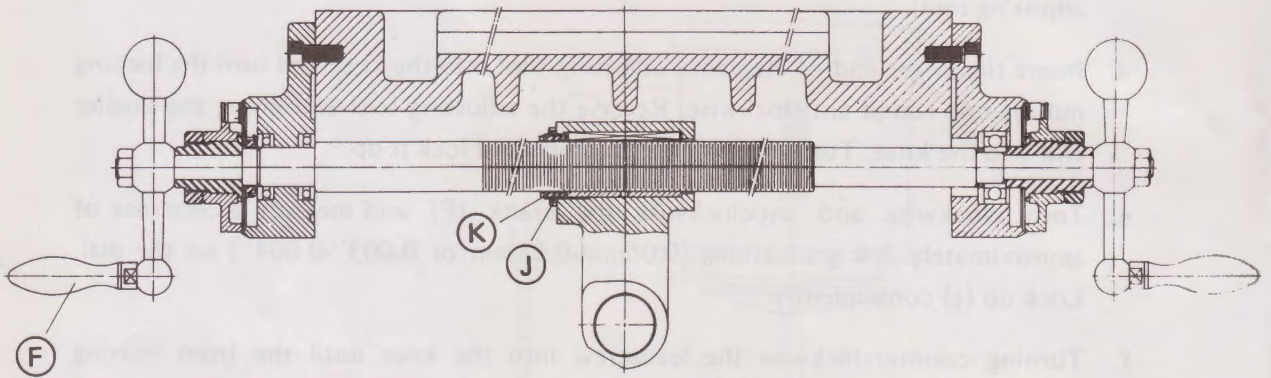

Figure 31

(6) Adjustment of Play between Gibs:

As a result of long-term operation between the sliding surface and gibs, the worn-out gibs will create a clearance. Therefore the gibs must be adjusted to upkeep the precision of sliding surfaces.

A. Adjustment of Work Table gibs (Vide Figure 32):

The gibs are attached onto between the saddle seat and work table dovetail.

- a. Loosen the lock lever (L).
- b. Clean the slideway and add the lubricant.
- c. Use a screwdriver and adjust the gib screw (M) on both sides of saddle seat.
- d. Adjusting skill: If the turning of crank (F) (Vide Figure 30, P. 30) is sensed too loose, loosen slightly the adjusting gib screw on the right side of saddle. Then, lock up the adjusting gib screw on the left side. Turn the crank again to see if it is in good tightness. Otherwise, loosen the left adjusting gib screw and lock the right one tightly. Repeat the same motion until the work table sliding is satisfactory.
- e. Replace the excessive worn-out gib whenever necessary.

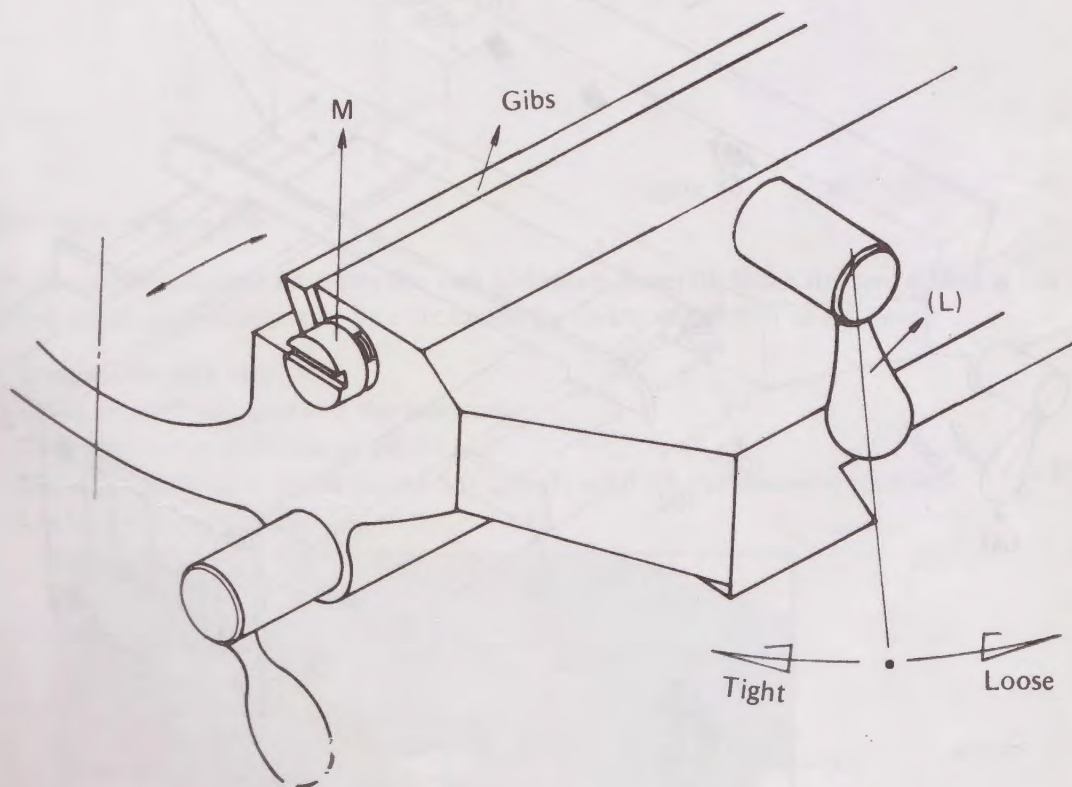

Figure 32

B. Adjustment of Saddle Gib (Vide Figure 33):

Saddle gib is attached to the position between the left side of saddle and knee dovetail. The adjustment can be performed as follows:

- a. Loosen the saddle lock bolt (A).
- b. Move the saddle to the front part of knee.
- c. Take off the wiper holder (B) of saddle.
- d. Clean the slideway and add the lubricant.
- e. Use a screw driver to adjust the gib screw (D) of the saddle.
- f. Employ the same methods to adjust the work table gib.
- g. Lock up the wiper holder (B) on the saddle.

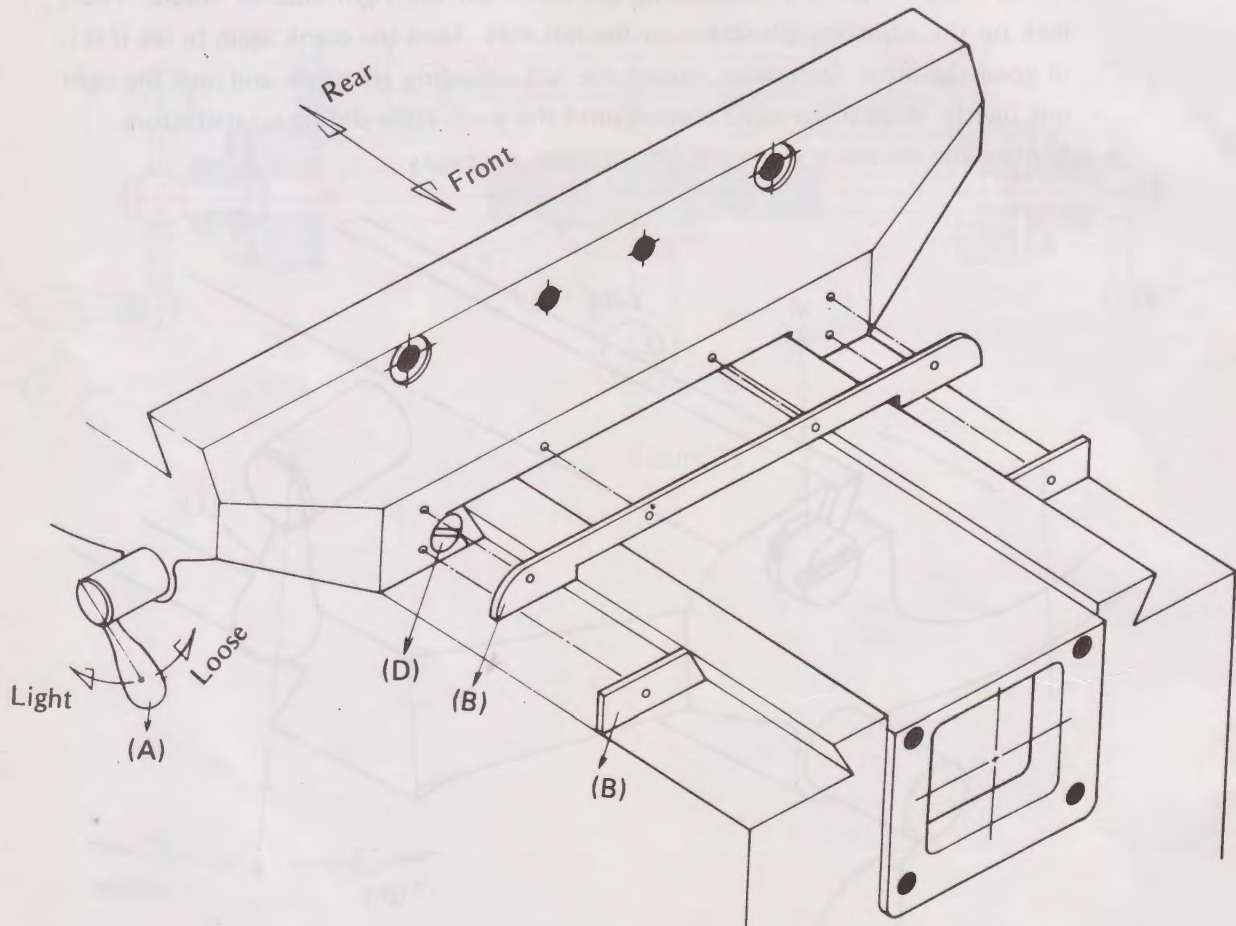

Figure 33

C. Adjustment of Knee Gib (Vide Figure 34):

The knee gib is attached to the position between the left side of knee and column dovetail. The adjustment can be performed as follows:

- a. Loosen the knee clamp lever (G) (Vide Figure 5, P. 5).
- b. Take off the wiper holder (Q).
- c. Clean the slideway and add the lubricant.
- d. Raise the knee to its upmost position.
- e. Use a screw driver to adjust the gib screw (R) of the knee.
- f. Employ the same methods to adjust the work table gib.
- g. Restore and lock up the wiper holder (Q).

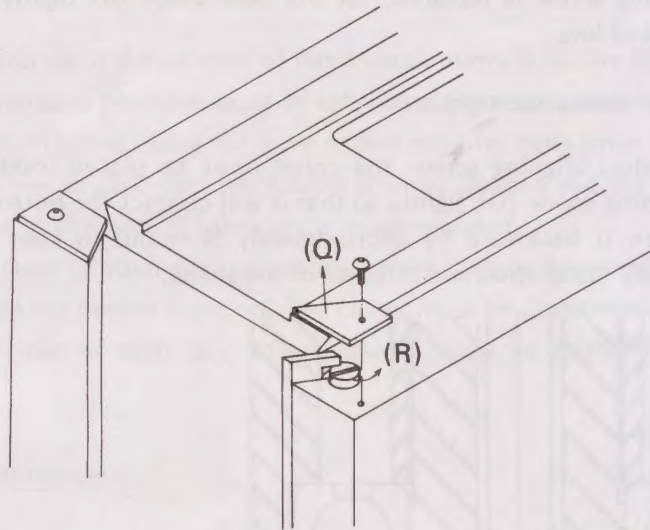

Figure 34

D. Adjustment of Ram Gib:

The ram gib is attached between the ram and turret dovetail. When the ram sliding is too tight or loose, adjustment may be effectuated by means of the bolt as follows:

- a. Loosen ram lock lever (C).
- b. Clean the slideway and add the lubricant.
- c. Turn the nut on the bolts of gib (I).
- d. Use a screw driver to set or loosen gib bolt (I) until the ram moves smoothly.
- e. Lock up the nut tightly.

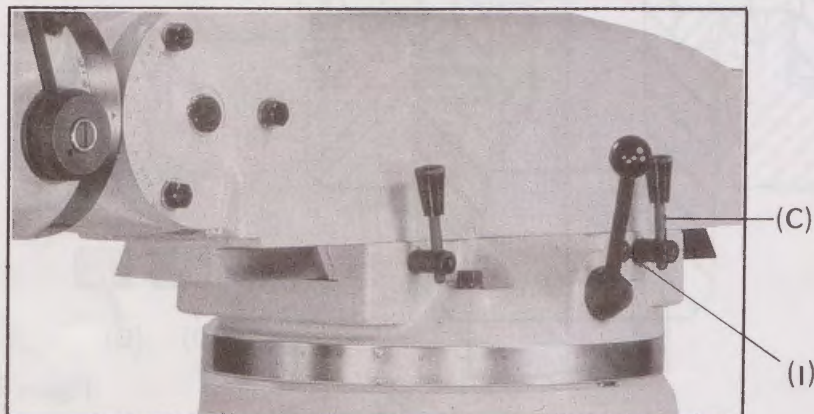

Figure 35

(5) Replacement of Collet Aligning Screw (Vide Figure 36): (Available for R8 spindle only)

- a. Prior to replacement, use a marking pencil to draw a line on quill (A) and its nose piece (B).
- b. Loosen the setting screw (C) nose piece. Use a hook spanner to take off the nose piece (B).
- c. Use a hexagonal spanner of appropriate length to take off the collet aligning screw (D) for replacement.
- d. When the collet aligning screw is replaced, set the nose piece (B) tightly until it is positioned on the marked line.
- e. Set the set screw (C) of nose piece tightly.

Note: To replace the collect aligning screw, the collet must be placed inside the quill. Set the collet aligning screw (D) tightly so that it will contact the bottom of screw keyway. Then turn it backward by approximately $\frac{1}{4}$ round to keep a 0.25mm (0.01") play for easy installation and removal of the shank.

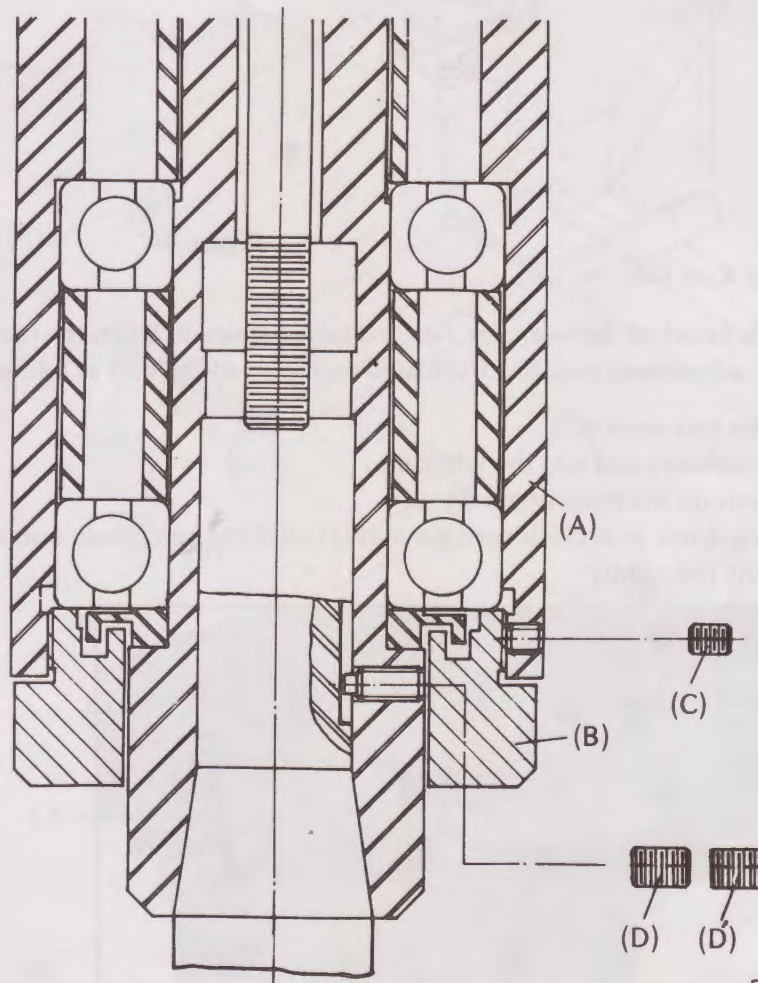

Figure 36

10) Maintenance:

“Maintenance is more important than repair; and repair is better than purchase”.

Under long-term operations, if the machine has not been properly maintained and operated, its service life shall be greatly reduced. The workpiece quality is therefore affected, and the efficiency, decreased. It is essential for an operator to know how to handle the machine and the concept of its maintenance and keep correctly.

Daily Maintenance:

- (1) Check and see if the oil level of hand crank pump is on the designated line.
- (2) The designated positions must be lubricated prior to operations (Vide Lubrication, P.8).
- (3) Keep the machine idling for three to five minutes daily prior to operations.
- (4) At the close of each day, work table shall be cleaned and the unfinished workpiece must be removed. A little bit of lubricant is recommended.
- (5) At the close of each day, all setting levers shall be loosened, and all sliding parts shall be moved to the proper position. The cutter must be dismantled.
- (6) At the close of each day, the headstock must be restored to its normal position if it is tilted.

Monthly Maintenance:

- (1) Check and see if all clamping rails of various sliding surfaces are normal.
- (2) Check and see if the backlash between leadscrew and its nut is normal.
- (3) Check and see if the quill lock and that of each and every sliding surface is normal.

Quarterly Maintenance:

- (1) Check and see if the brake functions and belt are normal.
- (2) Inspect the level of work table and erection status of headstock.
- (3) Test the machine again by the chart of test specs.
- (4) Replace whatever parts worn-out.

SPEED DIAGRAM (Motor 50 Hz)

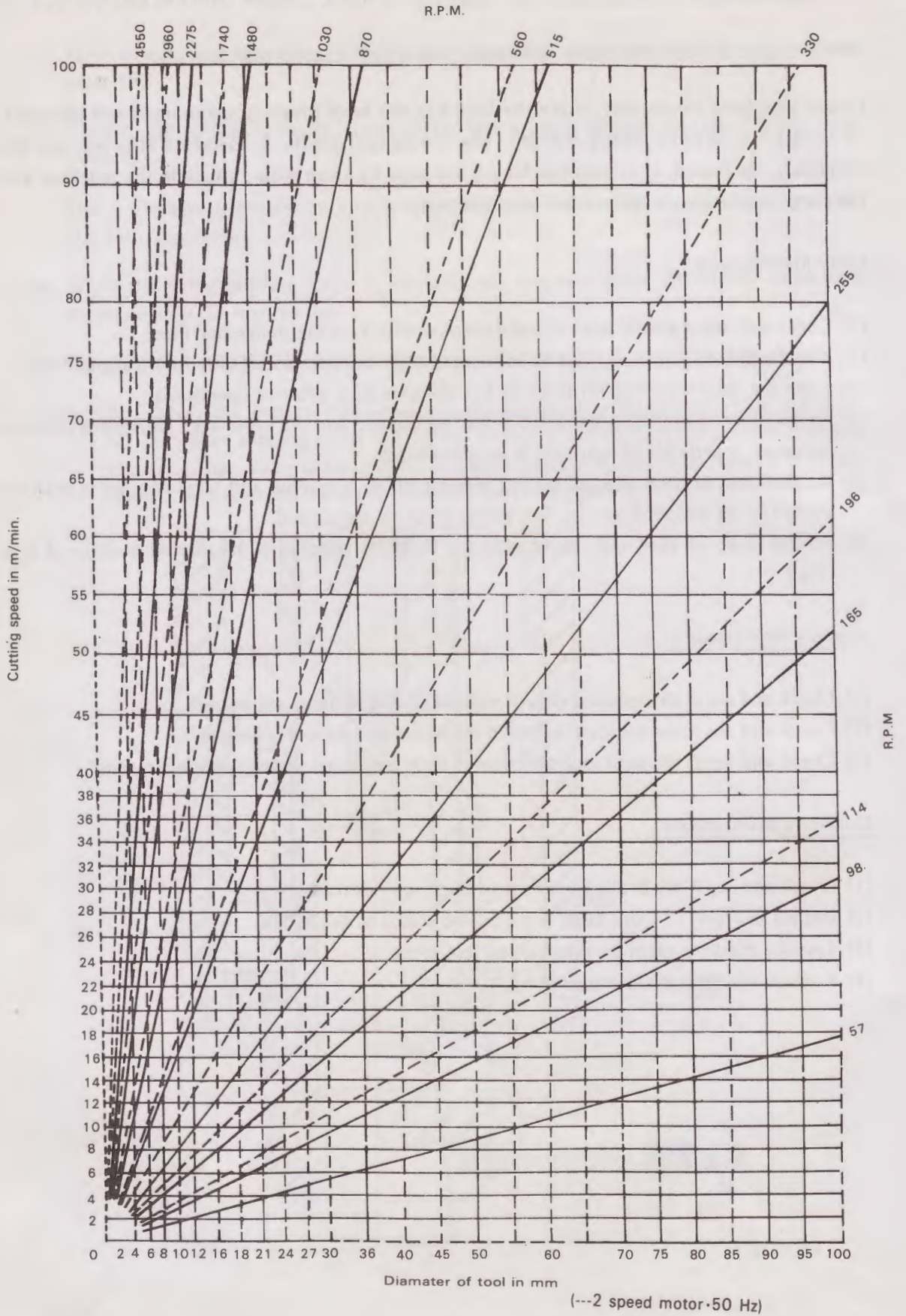

12) Cautions

(1) Machine operations:

- a. Check and ensure if the machine's bottom and ground base are properly contacted before lock up the anchor bolts.
- b. The machine must be installed upon a solid base.
- c. Check and see if the motor voltage and power source voltage are conformed.
- d. Cutters shall be far away from the workpieces when the motor is started or stopped.
- e. Switched off the power source before gear change.

(2) Machine Operators:

- a. The machine is to be started or operated by an authorized operator only.
- b. Immediate stop and repair are needed in case of troubles in operations.
- c. In installation, the machine shall be connected to earth.
- d. In stop motion, the feed lever shall be placed in the neutral position.
- e. The machine should be stopped during the inspection on the workpieces.
- f. In clamping, check and ensure if the workpieces are firmly vised.
- g. The spindle must be kept clean and lubricated all the time.
- h. Do not place any tools on the work table to maintain its surface preciseness and smoothness.
- i. Prior to cutting, wait until the spindle is running steadily after the motor is started.
- j. Use a brush to clean off the iron fragments.

12) Cautions

(1) Machine operations:

- a. Check and ensure if the machine's bottom and ground base are properly contacted before lock up the anchor bolts.
- b. The machine must be installed upon a solid base.
- c. Check and see if the motor voltage and power source voltage are conformed.
- d. Cutters shall be far away from the workpieces when the motor is started or stopped.
- e. Switched off the power source before gear change.

(2) Machine Operators:

- a. The machine is to be started or operated by an authorized operator only.
- b. Immediate stop and repair are needed in case of troubles in operations.
- c. In installation, the machine shall be connected to earth.
- d. In stop motion, the feed lever shall be placed in the neutral position.
- e. The machine should be stopped during the inspection on the workpieces.
- f. In clamping, check and ensure if the workpieces are firmly vised.
- g. The spindle must be kept clean and lubricated all the time.
- h. Do not place any tools on the work table to maintain its surface preciseness and smoothness.
- i. Prior to cutting, wait until the spindle is running steadily after the motor is started.
- j. Use a brush to clean off the iron fragments.

4. LC-1½TM Step Speed Milling Machine

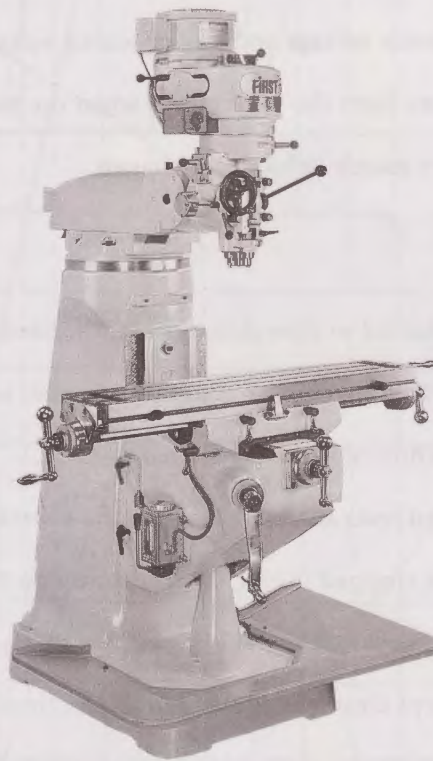

1) Specifications:

STANDARD					
SPECIFICATIONS	INCH	MM	SPECIFICATIONS	INCH	MM
WORK TABLE			Spindle speed	50Hz	68 115 185 285 540 910 1500 2280 (rpm)
Working area of table	42 x 9	1067 x 230	R.P.M.	60Hz	80 140 230 350 650 1100 1800 2760 (r.p.m)
Table travel (Hand)	30	762	Machine net weight	2,222Lb	1,010Kg
Saddle travel	12	305	A	56½	1,435
Knee travel	16	406	B	42	1,067
HEAD			C	0 - 12	0 - 305
Motor	2HP, 3PH		D	0 - 18½	0 - 469
Spindle taper	R8 or N.S.T. #30		E	0 - 12	0 - 305
Quill travel	5	127	F	6¾ - 18¾	171 - 476
Feed area (PER spindle revolution)	0.0015, 0.003, 0.006	0.04, 0.08, 0.15	G	8¾ - 20¾	222 - 527
OPTIONAL					
Working area of table	50 x 9	1270 x 230	Table travel (Hand)	37¾	960

2) Capacity (Vide P. 2)

3) Names of Machine Parts:

(1) Headstock:

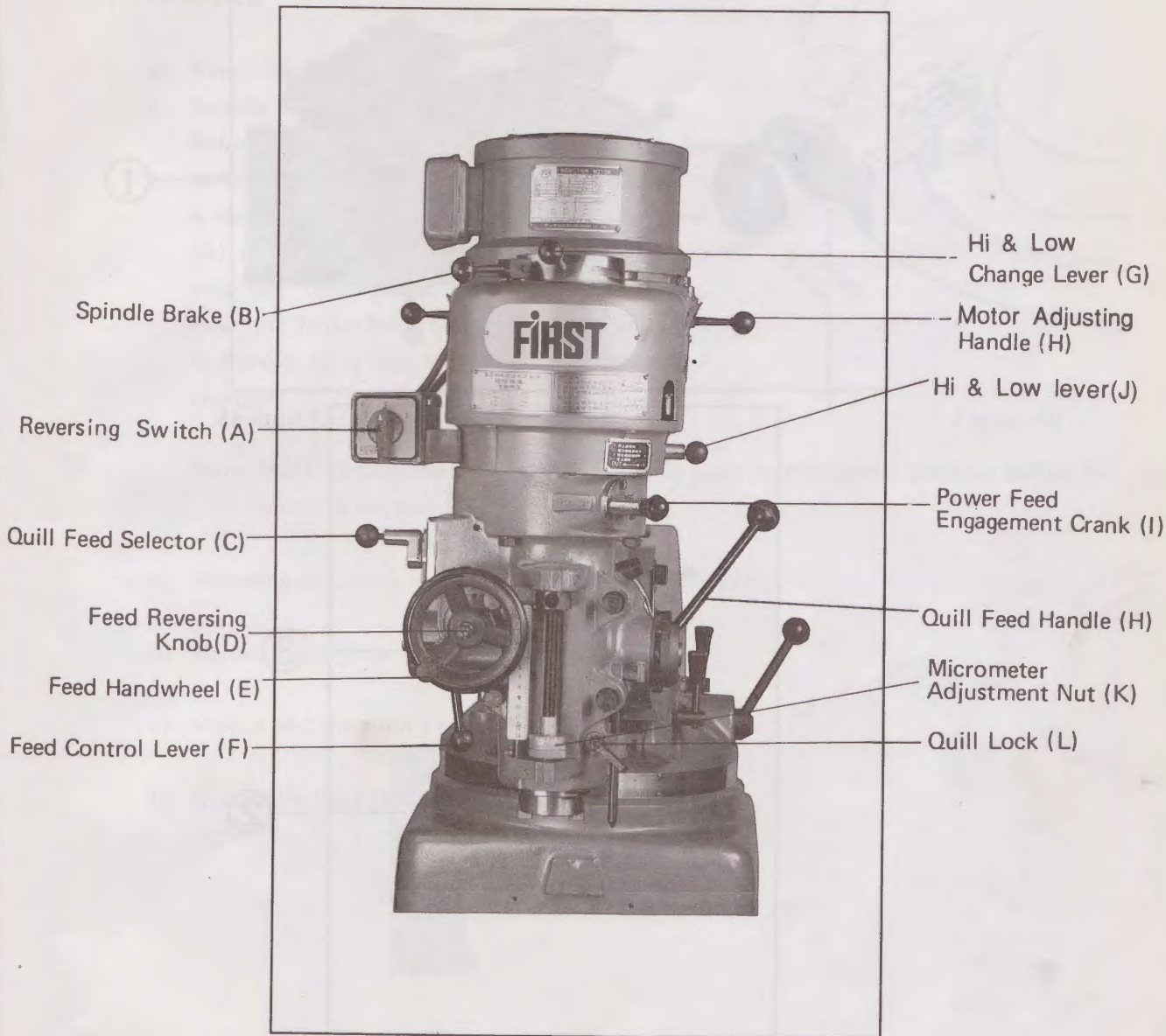

Figure 37

(2) Column, Head and Ram (Vide P. 4).

(3) Work Table, Saddle and Knee (Vide P. 5).

4) Lubrication

(1) Headstock Lubrication of LC-1½ TM

Proper lubrication is to ensure the precision degree and longer service life of the machine.

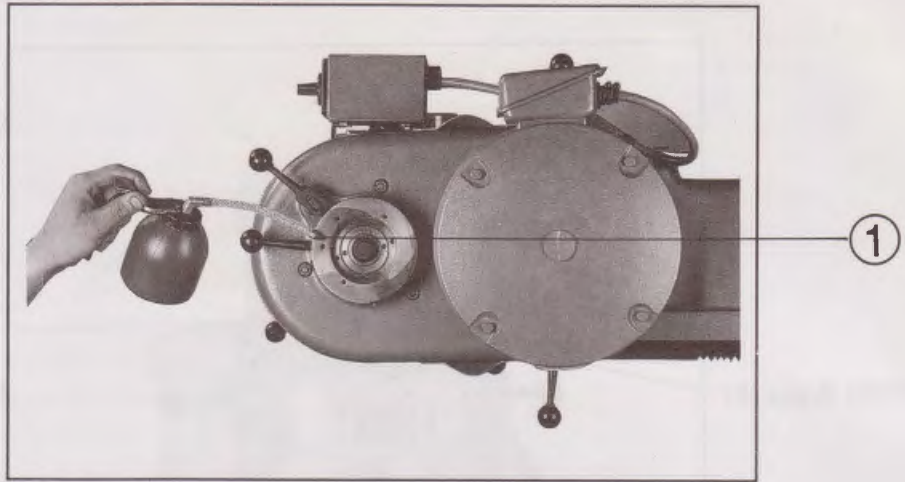

Figure 38

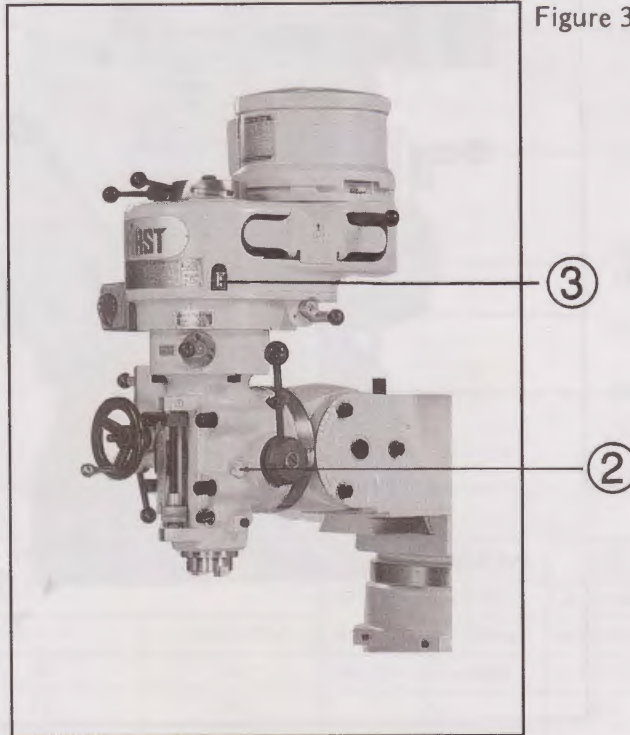

Figure 39

Item	Lubricants	Qty	Time	Position
1	KUO-KUANG R 68 ESSO FEBIS K 53	5-10 Drops	Twice Weekly	Clutch and Bearing Sleeve
2	GULF WAY 52	Full	Twice Daily	Head Stock Matching Quill Holes
3	VACTRA NO. 2 SHELL TONNA 33	Full	Twice Daily	Counter Shaft Gear Worm Gear Cradle

(2) Machine Table Lubrication (Vide P. 8)

5) Operation:

(1) Headstock:

- a) Reversing Switch (Vide P. 9)
- b) Spindle Brake:

Before braking, the power source must be switched off, and waiting until the spindle speed is lower than 200 RPM before the brake lever (A) is pushed to the left rear or left front to stop the turning and effectuate the braking. Push the brake lever (A) upward and the quill is braked to a full stop for easy cutter tool change.

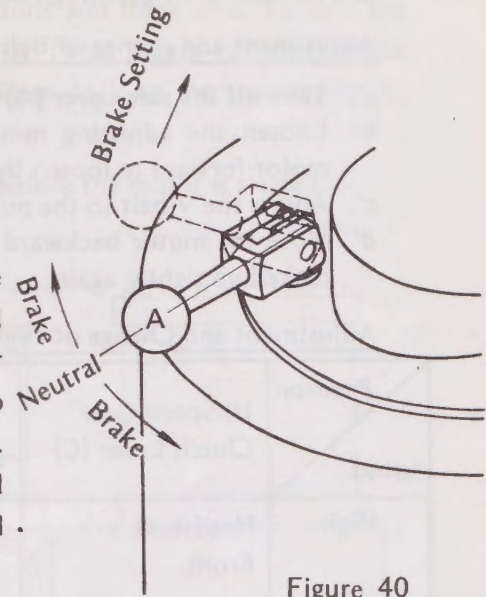

Figure 40

Note: Make certain the spindle brake lever is place at the neutral position before the motor is started.

- c) Chucking of tooling shank and dismantling (Vide P. 9).
- d) Manual Feed (Vide P. 10).
- e) Manual Micromotion Feed (Vide P. 10).
- f) Automatic Feed (Vide P. 11).

- (g) Change speed of spindle can be shift to the desired stage by changing the belt pulley and counter shaft gear (high or low speed).

Adjustment and change of Belt Pulley (Figure 41):

- a'. Take off the side cover (A) of front belt pulley.
- b'. Loosen the adjusting motor handle (B) as arrowed in the figure and move the motor forward to loosen the belt.
- c'. Adjust the V-belt to the pulley groove of the needed rotation speed.
- d'. Move the motor backward to regain the proper belt tension before the lever (B) is locked up tightly again.

Adjustment and Change of High and Low Speeds:

Speed \ Position	Hi-Speed Gear Clutch Lever (C)	Low-Speed Gear Clutch Lever (D)		Remarks
		IN	OUT	
High	Headstock's Front	OUT		Direct Drive by Clutch 60Hz: 650-2,760RPM 50Hz: 540-2,280RPM
Low	Headstock Right Side	IN		Counter shaft gear drive 60Hz: 80-350RPM 50Hz: 68-285 RPM
Neutral	"	OUT		
Dead Stop	Headstock's Front	IN		Do not use it.

Note: Low speed turning is in the reverse direction of the high speed. For the same direction of turning, use the reversing switch.

- a'. Make certain the spindle is completely motionless for gear shifting.
- b'. To change from high to low speed, the spindle must be slightly turned for the engagement of counter shaft gear.
- c'. To change from low to high gear, the spindle must be also slightly turned for clutch engagement. A "click" sound will be sensed at the time of engagement.

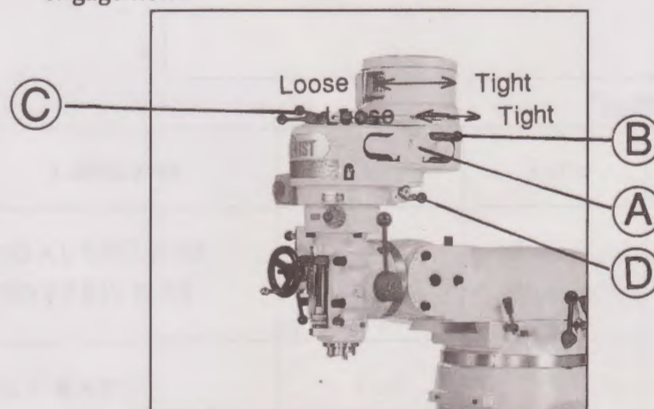

Figure 41

(h) Revolution of Gear Housing:

Machine head and gear housing are set by three T-Bolts and three nuts. To turn the gear housing, it is necessary to loosen slightly the nut (A) (Vide Figure 42) and exercise the strength on (B) to push it to the angle desired. Then, lock up the three bolts (A) evenly and tightly.

Note: Make certain to lock up the three bolts tightly before the motor is started.

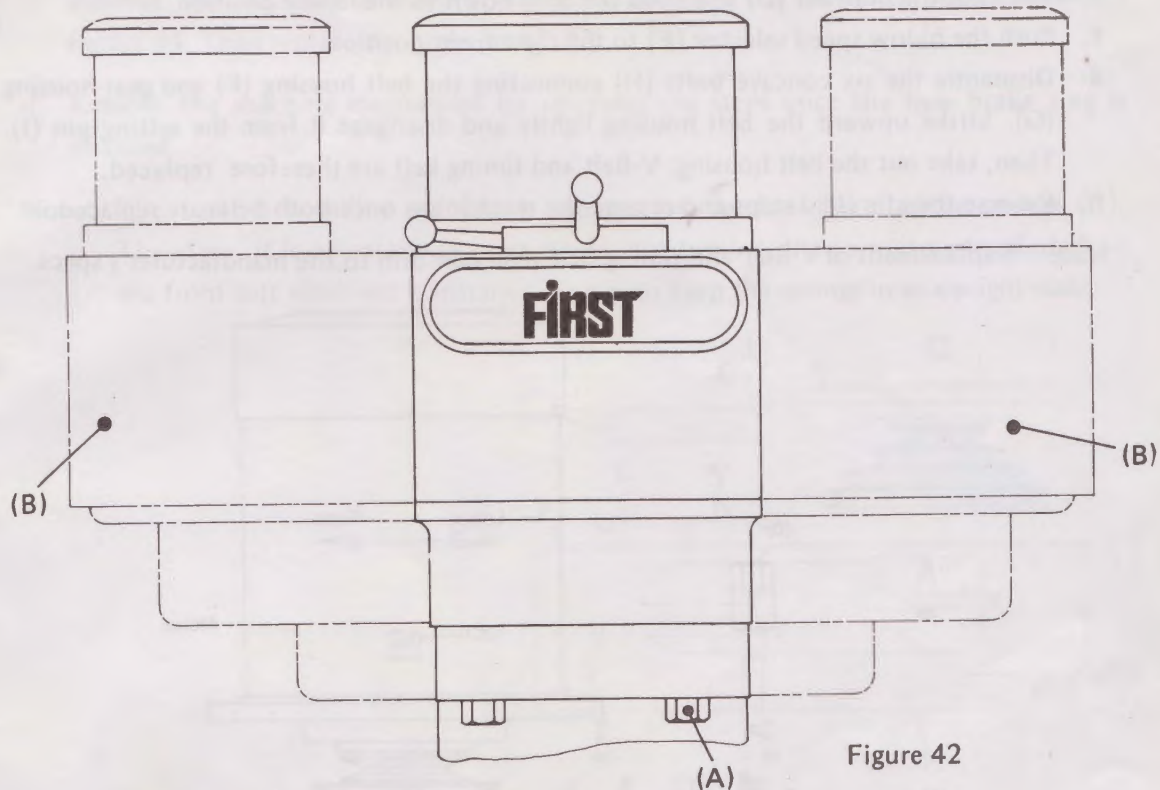

Figure 42

(i) Tilting of Machine Head (Vide P. 13):

2) Operations of Machine Body:

- a. Ram Movement and Swiveling (Vide P. 14).
- b. Zero Positioning of Dial Ring of Table Feed (Vide P. 15)
- c. Setting of Sliding surfaces of Work Table, Saddle Seat and Knee (Vide P. 15).
- d. Adjustment of backlash between leadscrews (Vide P. 30).
- e. Adjustment of Play between gibs (Vide P. 32).

6. Transport, Unpacking and Floor Space: (Vide P. 16)

7. Precision Alignment (Vide P. 20).

8) Trouble Shootings:

(1) Replacement of V-Belt and Timing Belt of 1½ TM Miller:

- a. Take up the wire grip and reversing switch.
- b. Take off the side cover of belt wheel housing (Vide Figure 41(A), P. 43).
- c. As illustrated in(Figure 43), loosen Adjusting motor handle (B) and move the motor forward to loosen the belt. Turn the V-Belt and let it slip off the belt wheel.
- d. Take off the two hexagonal nuts (C) for motor dismounting.
- e. Take out the drawbar (D) and drop the quill down to the lowest position.
- f. Push the hi-low speed selector (E) to the right front position.
- g. Dismantle the six concave bolts (H) connecting the belt housing (F) and gear housing (G). Strike upward the belt housing lightly and disengage it from the setting pin (I). Then, take out the belt housing. V-Belt and timing belt are therefore replaced.
- h. Reverse the aforesaid steps and restore the mechanism once both belts are replaced.

Note: Replacement of V-Belt and timing belt shall conform to the manufacturer's specs.

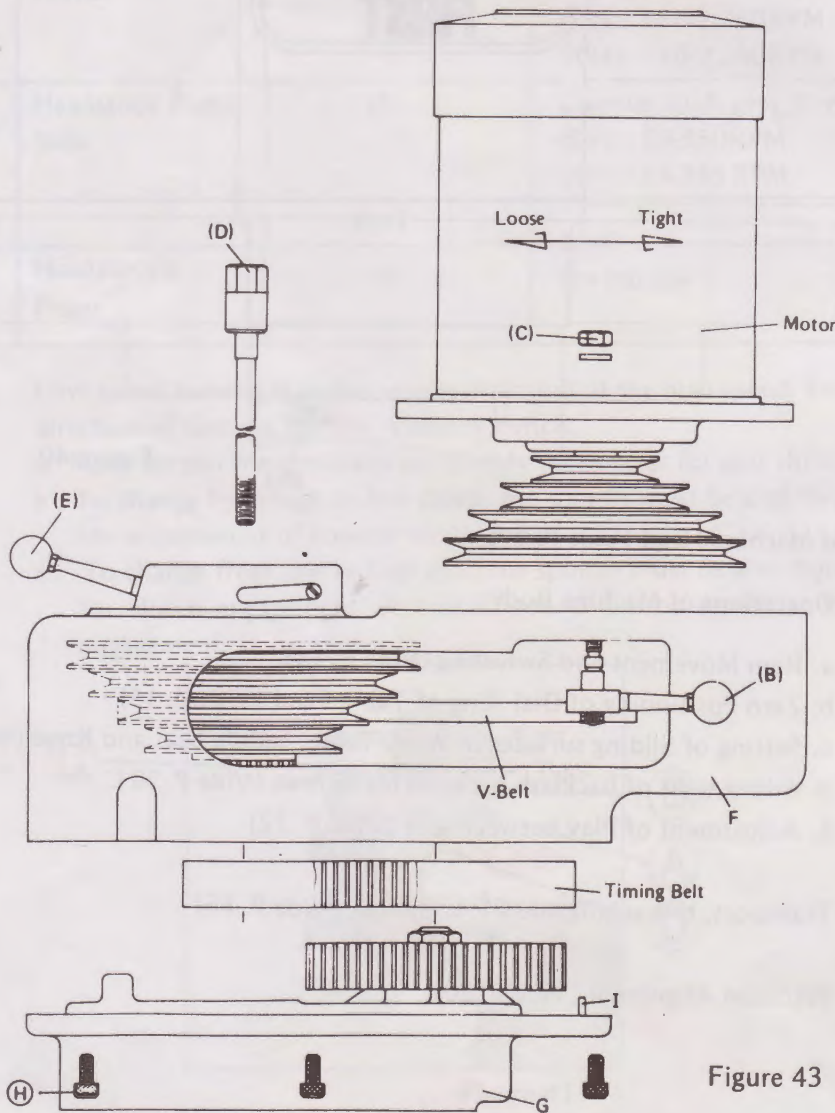

Figure 43

(2) Replacement of Brake Block of LC 1½ TM Miller:

- It is the same with the replacement step a to g of V-Belt and timing belt to take out the belt housing (F).
- Take off two M3 setting screws (J), two convex ring screws (K) and convex ring (L). Separate the belt housing (F) and front belt pulley set (M) and take out the four pressure springs (G).
- Remove the nuts (P) of three brake block and take off the bolts (R) as shown in Figure 44. Then replace the brake block (S).
- Restore the machine mechanism by reversing the steps once the new brake ring is installed.

Note: The front belt pulley set (M) is stopped by the four (4) pressure springs (G). Therefore, it is necessary to press down, not turning, the springs vertically before the front belt wheel set is installed. This is to keep the springs in an upright state.

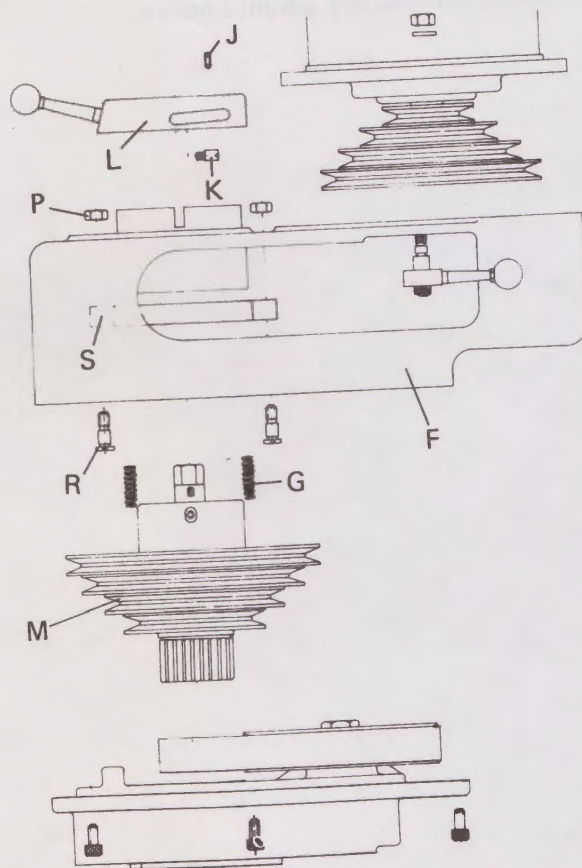

Figure 44

9) Maintenance (Vide P. 36).

10) Charts of Cutting (Vide P. 37)

11) Cautions (Vide P. 38).

(3) Adjustment of Backlash of Leadscrews (Vide P. 30).

(4) Adjustment of Play of Gibs. (Vide P. 32).

(5) Adjustment of Collet Aligning Screw (Vide P. 35).

5. Remarks

- 1) All LONG CHANG products, from parts to finished machines, have gone through different flows of process under strict QC Systems, with precision degrees in conformity with CNS (please vide charts of ex-factory inspection). To ensure the preciseness, service life and safety operations, it is highly advisable for the users to study the full details of this manual.
- 2) Suggestions for improvements of the machine structure and/or inquiries, including plant visitations, are cordially welcome.
- 3) In case of maintenance, servicing and parts changes, please contact our sales agencies or business department directly.
- 4) The manufacturer reserves the right to modify the design, operations, structure etc all of the machines without any advance notice.

